

***Our collection***

**2023**

CATALOGO GENERALE PRODOTTI  
PRODUCTS GENERAL CATALOGUE

CATÀLOGO GENERAL PRODUCTOS  
CATALOGUE GÉNÉRAL PRODUITS

# Welcome to **DPlus**

## **World-wide automation systems**



La qualità italiana è un pilastro su cui abbiamo scelto di investire, certi che sia la strategia vincente per offrire un servizio eccellente e duraturo. L'unione perfetta fra una squadra appassionata e la tecnologia più avanzata permette a **Dplus** di evolversi costantemente e di arricchire la propria gamma di prodotti per inserirsi al meglio in ogni contesto.



Italian quality is a pillar on which we have chosen to invest, certain that it is the winning strategy to offer an excellent and lasting service. The perfect union between a passionate team and the most advanced technology allows **Dplus** to constantly evolve and enrich its products range, to fit perfectly into any context.



La calidad italiana es un pilar en el que hemos elegido invertir, seguros de que es la estrategia ganadora para ofrecer un servicio excelente y duradero. La combinación perfecta entre un equipo apasionado y la tecnología más avanzada permite a **Dplus** evolucionar constantemente y enriquecer su gama de productos para adaptarse mejor a cada contexto.



La qualité italienne est un pilier dans lequel nous avons choisi d'investir, sûrs que c'est la stratégie gagnante pour offrir un service excellent et durable. L'union parfaite entre une équipe passionnée et la technologie la plus avancée permet à **Dplus** d'évoluer constamment et d'enrichir sa gamme de produits pour s'adapter au mieux à chaque contexte.



# Hoop

SMART HOME

## ***Discover Hoop!***

### ***Our new smart home collection***



Scopri anche la nuova collezione **Hoop**:

- Videocitofonia, disponibile in 2 fili analogico, 4 fili HD, 2 fili BUS
- Sistemi di Allarme Wireless, gestibili tramite smartphone, web, Alexa e Hey Google.

Prodotti sicuri e facili da installare, con alti standard di qualità a prezzi molto contenuti.



Discover also the new **Hoop** collection:

- Video Intercom, available in 2-wire analog, 4-wire HD, 2-wire BUS
- Wireless Alarm Systems, manageable via smartphone, web, Alexa and Hey Google

Safe and easy to install products, with high quality standards at very low prices.



Descubre también la nueva colección **Hoop**:

- Videoportero, disponible en 2 hilos analógico, 4 hilos HD, 2 hilos BUS
- Sistemas De Alarma Inalámbricos, gestionables a través de smartphone, web, Alexa y Hey Google

Productos seguros y fáciles de instalar con altos estándares de calidad a precios muy bajos.



Découvrez aussi la nouvelle collection **Hoop**:

- Vidéophonie, disponible en 2 fils analogique, 4 fils HD, 2 fils BUS
- Systèmes D'alarme Sans Fil, gérables via smartphone, web, Alexa et Hey Google

Des produits sûrs et faciles à installer avec des normes de qualité élevées à des prix très bas.







# Indice prodotti / Products index

Motorizzazioni specifiche suddivise per diverse tipologie di apertura, funzioni e dimensioni.  
Specific solutions following different types of opening, functions and dimensions.  
Motores específicos para diferentes tipos de apertura, funciones y tamaños  
Motorisations spécifiques divisées pour différents types d'ouverture, fonctions et tailles.



## **Scorrevoli**

*/ Sliding gates / Portones corredera / Portails coulissants ..... p. 04*



## **Battenti**

*/ Swing gates / Portones batientes / Portails battants ..... p. 22*



## **Porte basculanti**

*/ Garage doors / Puertas de garaje / Portes de garage ..... p. 42*



## **Barriere stradali**

*/ Barriers / Barreras vehiculares / Barrières ..... p. 54*



## **Porte automatiche**

*/ Automatic sliding doors / Puertas automaticas / Portes automatiques ..... p. 62*



## **Accessori**

*/ Accessories / Accesorios / Accessoires ..... p. 72*

# **Scorrevoli**

**Sliding gates / Portones corredera / Portails couissants**

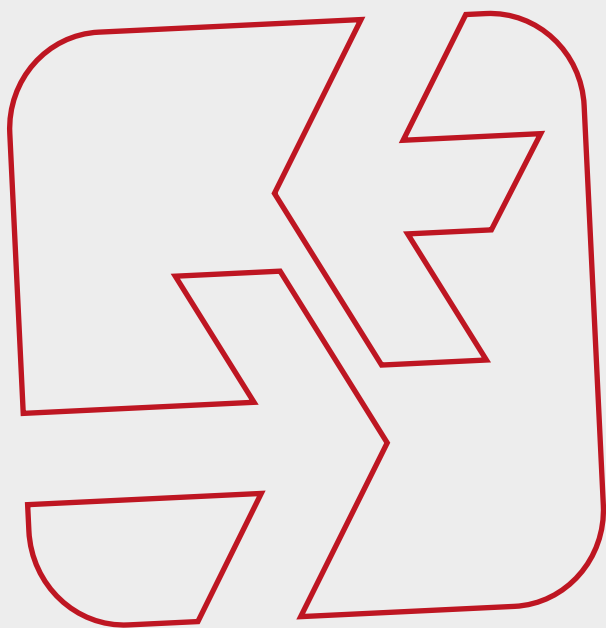

**Kiko**

**City**

**Idea**

**Bull**

**Mega5**

**Accessories**



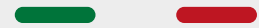

# Kiko

100% Produced in Italy



## 110/230 Vac

 **Kiko** è un motoriduttore elettromeccanico per cancelli scorrevoli fino a 600kg

 **Kiko** is an electromechanical gear motor for sliding gates up to 600kg

 **Kiko** es un motoreductor electromecánico para puertas correderas para 600kg

 **Kiko** est un opérateur électromécanique pour portails coulissants de 600kg

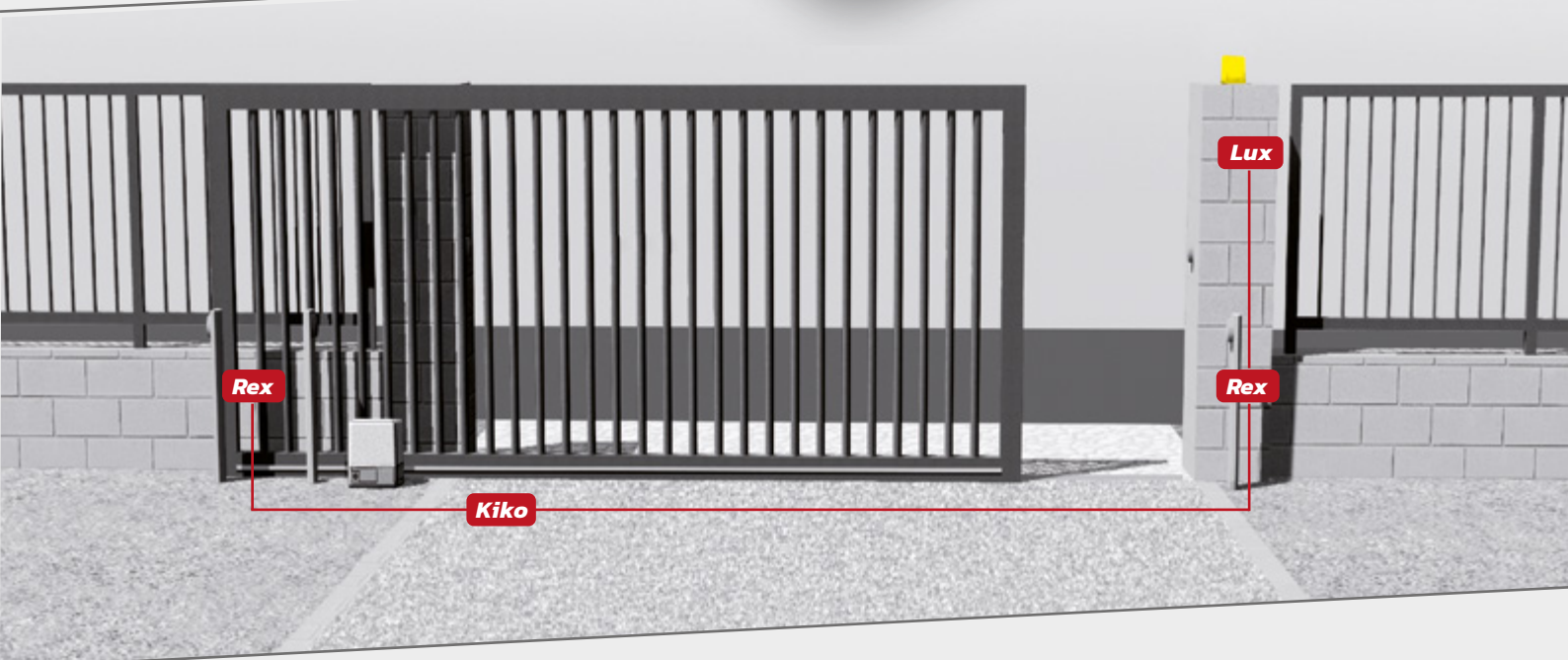

**DATI TECNICI / TECHNICAL DATA**
**Kiko**

ALIMENTAZIONE GENERALE / MAIN POWER SUPPLY	110/230 Vac
ALIMENTAZIONE / MOTOR POWER SUPPLY	230 Vac
TEMPERATURA DI ESERCIZIO / OPERATING TEMPERATURE	-20° +55°
PESO MASSIMO ANTA / MAXIMUM LEAF WEIGHT	600 KG
POTENZA / MOTOR POWER	250 W
CONDENSATORE / CAPACITOR	10 µF
MANOVRA DI EMERGENZA / MECHANICAL UNLOCK	WHITE KEY
GRADO IP / IP	44
PESO MOTORE / WEIGHT	8 KG
VELOCITÀ DI APERTURA / OPENING TIME	10 M/MIN

**Kiko**

200      400      600      800 Kg

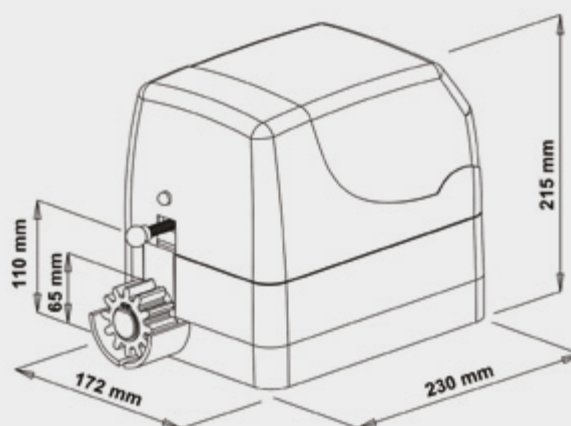

- Peso massimo dei cancelli azionabili dai motori della gamma **Kiko**.
- Maximum capacity of **Kiko** operators..
- Peso máximo de las puertas por los motores de la gama **Kiko**.
- Poids maximum des portails entraînés par les opérateurs **Kiko**.

**Kiko/ 600Kg**

- Motoriduttore 230Vac
- Centrale METRA230



- Electromechanical operator 230Vac
- Control unit METRA230



- Motoreductor de 230Vac
- Controladora METRA230

**Cod. 1022000 / € 360,00**

- Opérateur à 230Vac
- Centrale de commande METRA230

**Kit small**
**Kiko/ 600Kg**

- Motoriduttore 230 Vac
- Centrale METRA230
- 2 telecomandi STAR2

- Electromechanical operator 230Vac
- Control unit METRA230
- 2 Remote controls STAR2

- Motoreductor de 230Vac
- Controladora METRA230
- 2 Mandos STAR2

**Cod. 1021000 / € 384,00**

- Opérateur à 230Vac
- Centrale de commande METRA230
- 2 Télécommandes STAR2

**Kit top**
**Kiko/ 600Kg**

- Motoriduttore 230 Vac
- Centrale METRA230
- 2 telecomandi STAR2
- REX20 fotocellule
- LUX lampeggiante

- Electromechanical operator 230Vac
- Control unit METRA230
- 2 Remote controls STAR2
- REX20 photocells
- LUX flashing light

- Motoreductor de 230Vac
- Controladora METRA230
- 2 Mandos STAR2
- REX20 fotocélulas
- LUX lámpara

**Cod. 1020000 / € 438,00**

- Opérateur à 230Vac
- Centrale de commande METRA230
- 2 Télécommandes STAR2
- REX20 photocellules
- LUX lampe clignotante





# City

110/230 Vac  
24 Vdc

100% Produced in Italy



 **City** è un motoriduttore elettromeccanico per cancelli scorrevoli. Gamma motori con portate 600, 800, 1200 kg (230 Vac) e 800 kg (24 Vdc)

 **City** is an electromechanical gear operator for sliding gates. Range of operators 600, 800, 1200 kg (230 Vac) and 800 kg (24 Vdc)

 **City** es un motoreductor electromecánico para puertas correderas. Gama de motores para 600, 800, 1200 kg (230 Vac) y 800 kg (24 Vdc)

 **City** est un opérateur électromécanique pour portails coulissants. Gamme de moteurs: 600, 800, 1200 kg (230 Vac) et 800 kg (24 Vdc)

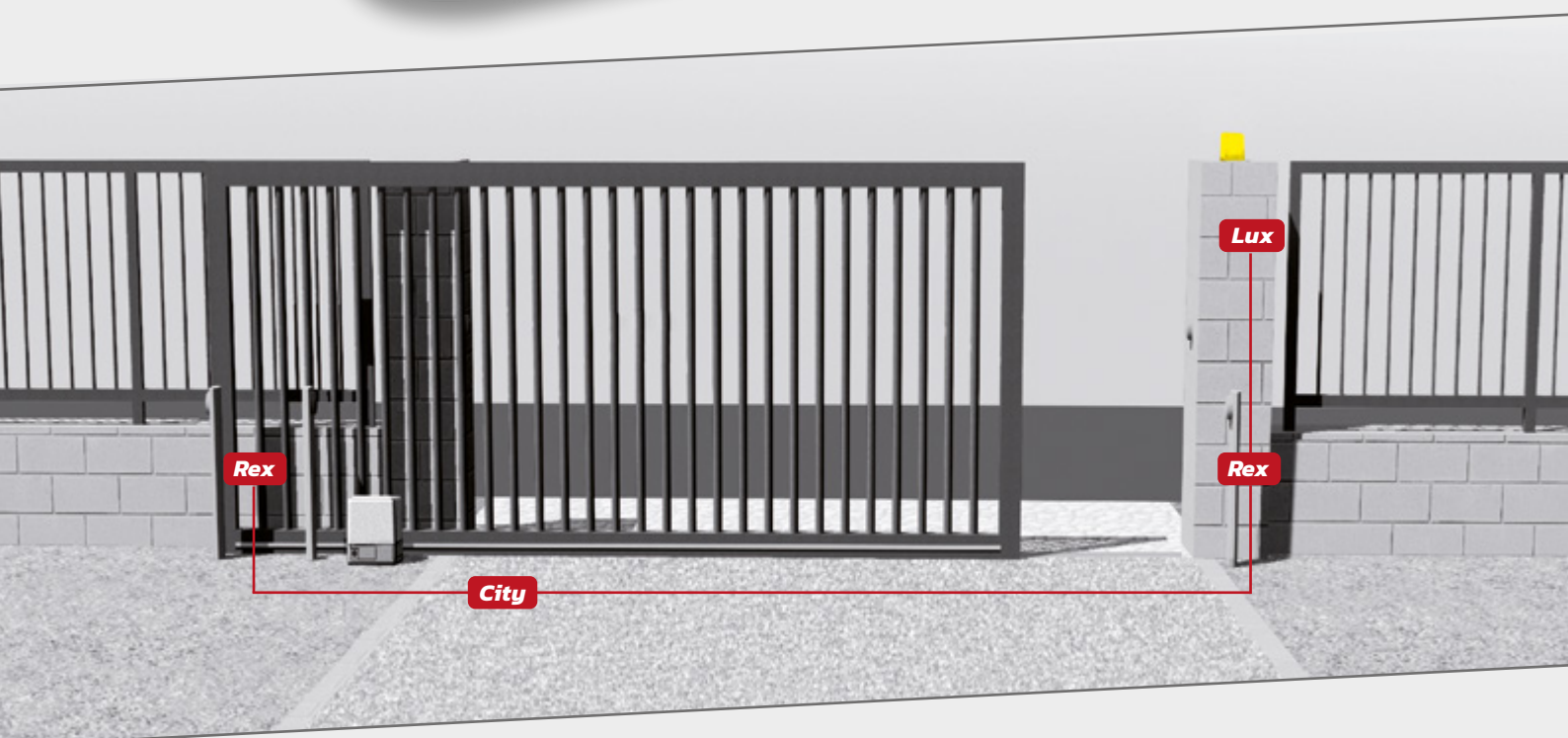

DATI TECNICI / TECH. DATA	<i>City 600 Speed</i>	<i>City 600</i>	<i>City 800</i>	<i>City 80024</i>	<i>City 1200</i>
ALIMENTAZIONE GENERALE / MAIN POWER SUPPLY	110/230 Vac	110/230 Vac	110/230 Vac	110/230 Vac	110/230 Vac
ALIMENTAZIONE MOTORE / POWER SUPPLY	230 Vac 50/60 Hz	110/230 Vac 50/60 Hz	110/230 Vac 50/60 Hz	24 Vdc 50/60 Hz	110/230 Vac 50/60 Hz
TEMPERATURA DI ESERCIZIO / OPERATING TEMPERATURE	-20° +55°	-20° +55°	-20° +55°	-20° +55°	-20° +55°
PESO MASSIMO CANCELLO / MAXIMUM GATE WEIGHT	600 KG	600 KG	800 KG	800 KG	1200 KG
POTENZA / RATED POWER	300 W	300 W	320 W	50 W	340 W
ASSORBIMENTO / ABSORBED POWER	2 A	1,8 A	2 A	4 A	2,2 A
CONDENSATORE / CAPACITOR	12,5 µF	10 µF	12,5 µF	-	16 µF
GRADO IP / IP	44	44	44	44	44
PESO MOTORE / WEIGHT	10 KG	10 KG	10 KG	10 KG	10 KG
VELOCITÀ DI APERTURA / OPENING TIME	18 M/MIN	10 M/MIN	10 M/MIN	10 M/MIN	10 M/MIN

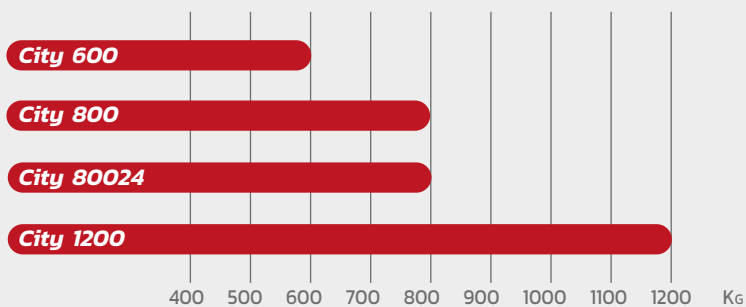

- Peso massimo dei cancelli azionabili dai motori della gamma *City*.
- Maximum capacity of *City* operators..
- Peso máximo de las puertas por los motores de la gama *City*.
- Poids maximum des portails entraînés par les opérateurs *City*.

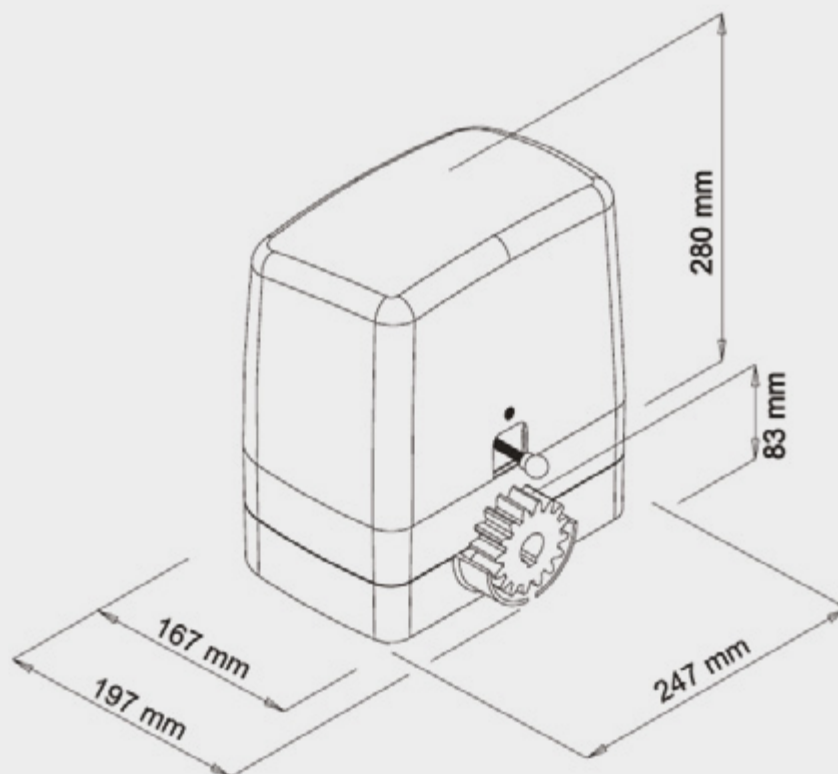





**City 600 / 600 Kg**

**Cod. 1001000 / € 425,00**

**City 800 / 800 Kg**

**Cod. 1101000 / € 467,00**

**City 1200 / 1200 Kg**

**Cod. 1201000 / € 510,00**

**City 600 SPEED / 600 Kg**

**Cod. 1301000 / € 470,00**

**City 24 (24 Vdc) / 800 Kg**

**Cod. 1241000 / € 506,00**

- Motoriduttore a 230Vac e 24Vdc
- Centrale (METRA230 / METRA24) con ricevente inclusa

- Electro-mechanical operator 230Vac and 24Vdc
- Control unit (METRA230 / METRA24) with built-in receiver

- Motoreductor de 230Vac y 24Vdc
- Controladora (METRA230 / METRA24) con receptor incorporado

- Opérateur à 230Vac et 24Vdc
- Centrale de commande (METRA230 / METRA24) avec récepteur incorporé

## Kit small

**City 600 / 600 Kg**

**Cod. 1001200 / € 455,00**

**City 800 / 800 Kg**

**Cod. 1101200 / € 500,00**

**City 1200 / 1200 Kg**

**Cod. 1201200 / € 546,00**

**City 600 SPEED / 600 Kg**

**Cod. 1301200 / € 500,00**

**City 24 (24 Vdc) / 800 Kg**

**Cod. 1241200 / € 550,00**

- Motoriduttore a 230Vac e 24Vdc
- Centrale (METRA230 / METRA24)
- 2 telecomandi STAR2

- Electro-mechanical operator 230Vac and 24Vdc
- Control unit (METRA230 / METRA24)
- 2 remote controls STAR2

- Motoreductor de 230Vac y 24Vdc
- Controladora (METRA230 / METRA24)
- 2 mandos STAR2

- Opérateur à 230Vac et 24Vdc
- Centrale de commande (METRA230 / METRA24)
- 2 télécommandes STAR2

## Kit top

**City 600 / 600 Kg**

**Cod. 1001211 / € 510,00**

**City 800 / 800 Kg**

**Cod. 1101211 / € 561,00**

**City 1200 / 1200 Kg**

**Cod. 1201211 / € 612,00**

**City 600 SPEED / 600 Kg**

**Cod. 1301211 / € 555,00**

**City 24 (24 Vdc) / 800 Kg**

**Cod. 1241211 / € 610,00**

- Motoriduttore a 230Vac e 24Vdc
- Centrale (METRA230 / METRA24)
- REX20 fotocellule
- LUX lampeggiante
- 2 telecomandi STAR2

- Electro-mechanical operator 230Vac and 24Vdc
- Control unit (METRA230 / METRA24)
- REX20 photocells
- LUX flashing light
- 2 remote controls STAR2

- Motoreductor de 230Vac y 24Vdc
- Controladora (METRA230 / METRA24)
- REX20 fotocélulas
- LUX làmpara
- 2 mandos STAR2

- Opérateur à 230Vac et 24Vdc
- Centrale de commande (METRA230 / METRA24)
- REX20 photocellules
- LUX lampe clignotante
- 2 télécommandes STAR2

# Idea

100% Produced in Italy

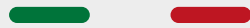



## 110/230 Vac



 **Idea** è un motoriduttore elettromeccanico per cancelli scorrevoli con riduzione in bagno d'olio. Gamma motori con portata 1200kg e 1600kg

 **Idea** is an electromechanical gear motor for sliding gates with gearing in oil bath. Range of operators 1200kg and 1600kg

 **Idea** es un motoreductor electromecanico para puertas corredizas con el reductor en bano de aceite. Gama de motores 1200kg y 1600kg

 **Idea** est un opérateur électromécanique pour portails coulissants avec engranages en bain d'huile. Gamme de moteurs 1200kg et 1600kg

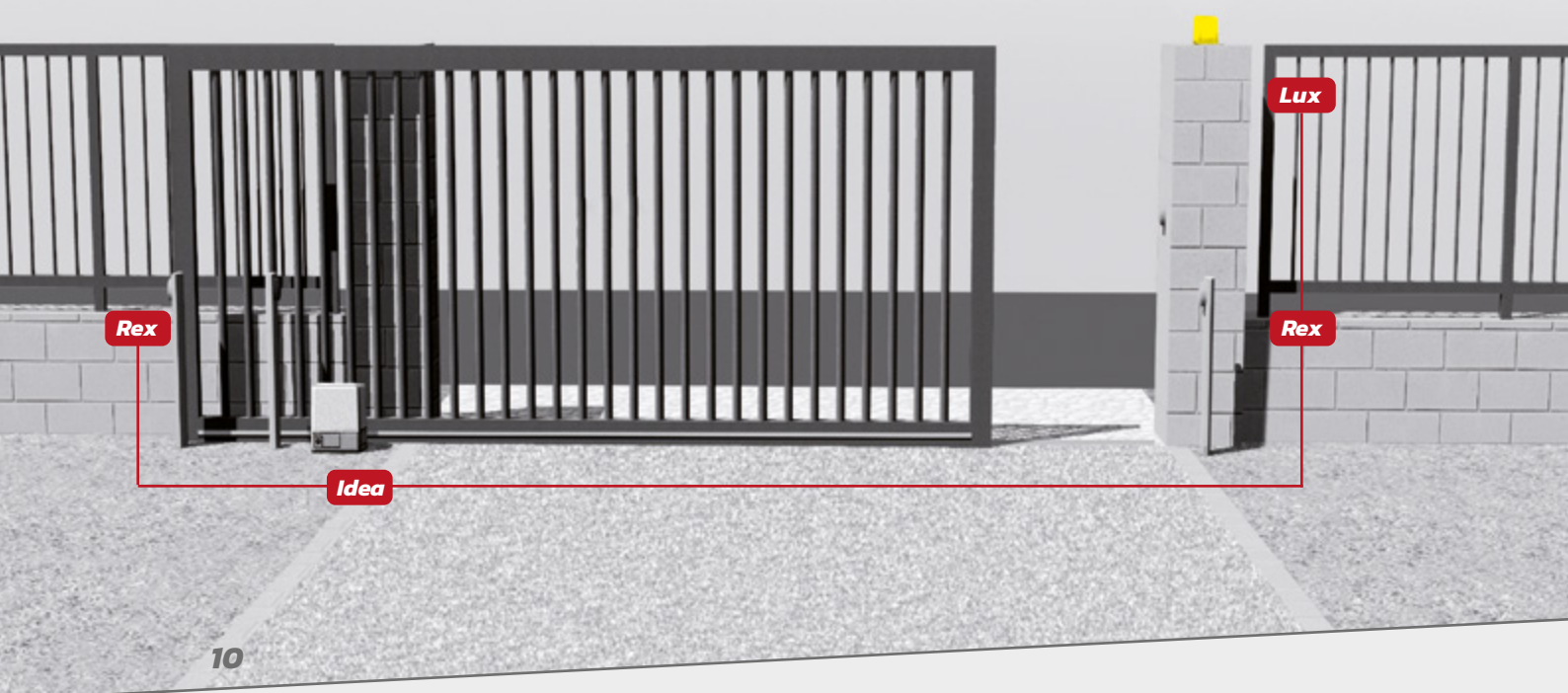



DATI TECNICI / TECHNICAL DATA	<i>Idea 1200</i>	<i>Idea 1600</i>	<i>Idea Inverter</i>
ALIMENTAZIONE GENERALE / MAIN POWER SUPPLY	230 Vac	110/230 Vac	110/230 Vac
ALIMENTAZIONE MOTORE / POWER SUPPLY	230 Vac	110/230 Vac	110/230 Vac
TEMPERATURA DI ESERCIZIO / OPERATING TEMPERATURE	-20° +55°	-20° +55	-20° +55
PESO MASSIMO ANTA / MAXIMUM LEAF WEIGHT	1200 KG	1600 KG	1800 KG
POTENZA / RATED POWER	330 W	360 W	400 W
CONDENSATORE / CAPACITOR	16 µF	18 µF	-
GIRI MOTORE / ENGINE REVOLUTIONS	1400 RPM	1400 RPM	1400 RPM
GRADO IP / IP	44	44	44
PESO MOTORE / WEIGHT	13 KG	13 KG	13 KG
VELOCITÀ DI APERTURA / OPENING TIME	9,5 M/MIN	9,5 M/MIN	9,5 M/MIN

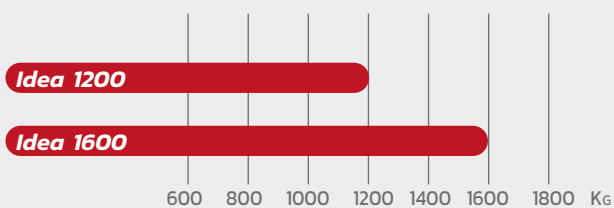

- Peso massimo dei cancelli azionabili dai motori della gamma *Idea*.
- Maximum capacity of *Idea* operators.
- Peso máximo de las puertas por los motores de la gama *Idea*.
- Poids maximum des portails entraînés par les opérateurs *Idea*.

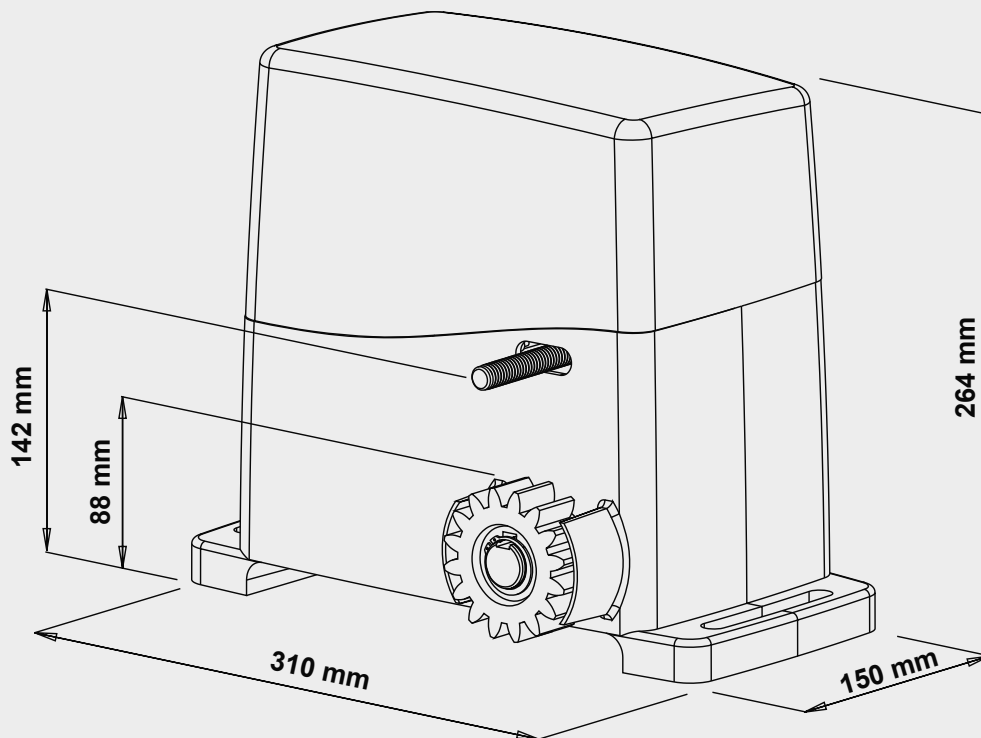

# Idea



## Idea 1200 Oil / 1200Kg

**Cod. 1403010 / € 615,00**

Motoriduttore 230Vac con riduzione in bagno d'olio, centrale METRA230

Electromechanical operator 230Vac with gearing in oil bath, control unit METRA230

Motoreductor de 230Vac con reductor en bano de aceite, controladora METRA230

Opérateur à 230Vac avec engranages en bain d'huile, centrale de commande METRA230

## Idea 1600 Oil / 1600Kg

**Cod. 1402000 / € 635,00**

Motoriduttore 110/230Vac con riduzione in bagno d'olio, centrale METRA

Electromechanical operator 110/230Vac with gearing in oil bath, control unit METRA

Motoreductor de 110/230Vac con reductor en bano de aceite, controladora METRA

Opérateur à 110/230Vac avec engranages en bain d'huile, centrale de commande METRA

## Idea 1600 Oil Inverter / 1600Kg

**Cod. 1402020 / € 786,00**

Motoriduttore 110/230Vac con riduzione in bagno d'olio, centrale INVER23

Electromechanical operator 110/230Vac with gearing in oil bath, control unit INVER23

Motoreductor de 110/230Vac con reductor en bano de aceite, controladora INVER23

Opérateur à 110/230Vac avec engranages en bain d'huile, centrale de commande INVER23

## Kit small

### Idea 1200 Oil / 1200Kg

**Cod. 1403210 / € 645,00**

Motoriduttore 230Vac con riduzione in bagno d'olio, centrale METRA230, 2 telecomandi STAR2

Electromechanical operator 230Vac with gearing in oil bath, control unit METRA230, 2 remote controls STAR2

Motoreductor de 230Vac con reductor en bano de aceite, controladora METRA230, 2 mandos STAR2

Opérateur à 230Vac avec engranages en bain d'huile, centrale de commande METRA230, 2 télécommandes STAR2

### Idea 1600 Oil / 1600Kg

**Cod. 1402200 / € 665,00**

Motoriduttore 110/230Vac con riduzione in bagno d'olio, centrale METRA, 2 telecomandi STAR2

Electromechanical operator 110/230Vac with gearing in oil bath, control unit METRA, 2 remote controls STAR2

Motoreductor de 110/230Vac con reductor en bano de aceite, controladora METRA, 2 mandos STAR2

Opérateur à 110/230Vac avec engranages en bain d'huile, centrale de commande METRA, 2 télécommandes STAR2

### Idea 1600 Oil Inverter / 1600Kg

**Cod. 1402220 / € 816,00**

Motoriduttore 110/230Vac con riduzione in bagno d'olio, centrale INVER23, 2 telecomandi STAR2

Electromechanical operator 110/230Vac with gearing in oil bath, control unit INVER23, 2 remote controls STAR2

Motoreductor de 110/230Vac con reductor en bano de aceite, controladora INVER23, 2 mandos STAR2

Opérateur à 110/230Vac avec engranages en bain d'huile, centrale de commande INVER23, 2 télécommandes STAR2

## Kit top



### Idea 1200 Oil / 1200Kg

**Cod. 1403311 / € 712,00**

Motoriduttore 230Vac con riduzione in bagno d'olio, centrale METRA230, 2 telecomandi STAR2, REX20 fotocellule, LUX lampeggiante

Electromechanical operator 230Vac with gearing in oil bath, control unit METRA230, 2 remote controls STAR2, REX20 photocells, LUX flashing light

Motoreductor de 230Vac con reductor en bano de aceite, controladora METRA230, 2 mandos STAR2, REX20 fotocelulas, LUX làmpara

Opérateur à 230Vac avec engranages en bain d'huile, centrale de commande METRA230, 2 télécommandes STAR2, REX20 photocellules, LUX lampe clignotante

### Idea 1600 Oil / 1600Kg

**Cod. 1402211 / € 732,00**

Motoriduttore 110/230Vac con riduzione in bagno d'olio, centrale METRA, 2 telecomandi STAR2, REX20 fotocellule, LUX lampeggiante

Electromechanical operator 110/230Vac with gearing in oil bath, control unit METRA, 2 remote controls STAR2, REX20 photocells, LUX flashing light

Motoreductor de 110/230Vac con reductor en bano de aceite, controladora METRA, 2 mandos STAR2, REX20 fotocelulas, LUX làmpara

Opérateur à 110/230Vac avec engranages en bain d'huile, centrale de commande METRA, 2 télécommandes STAR2, REX20 photocellules, LUX lampe clignotante

### Idea 1600 Oil Inverter / 1600Kg

**Cod. 1402221 / € 883,00**

Motoriduttore 110/230Vac con riduzione in bagno d'olio, centrale INVER23, 2 telecomandi STAR2, REX20 fotocellule, LUX lampeggiante

Electromechanical operator 110/230Vac with gearing in oil bath, control unit INVER23, 2 remote controls STAR2, REX20 photocells, LUX flashing light

Motoreductor de 110/230Vac con reductor en bano de aceite, controladora INVER23, 2 mandos STAR2, REX20 fotocelulas, LUX làmpara

Opérateur à 110/230Vac avec engranages en bain d'huile, centrale de commande INVER23, 2 télécommandes STAR2, REX20 photocellules, LUX lampe clignotante

# Bull

## 110/230/380 Vac



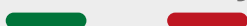

100% Produced in Italy



 **Bull** è un motoriduttore elettromeccanico per cancelli scorrevoli con riduzione in bagno d'olio. Gamma motori con portata 2000kg monofase e 2500kg trifase

 **Bull** is an electromechanical gear motor for sliding gates with gearing in oil bath. Range of operators 2000kg single phase and 2500kg three phase

 **Bull** es un motoreductor electromecánico para puertas corredizas con el reductor en baño de aceite. Gama de motores 2000kg monofásico y 2500kg trifásico phase

 **Bull** est un opérateur électromécanique pour portails coulissants avec engranages en bain d'huile. Gamme de moteurs 2000kg monophasé et 2500kg triphasé

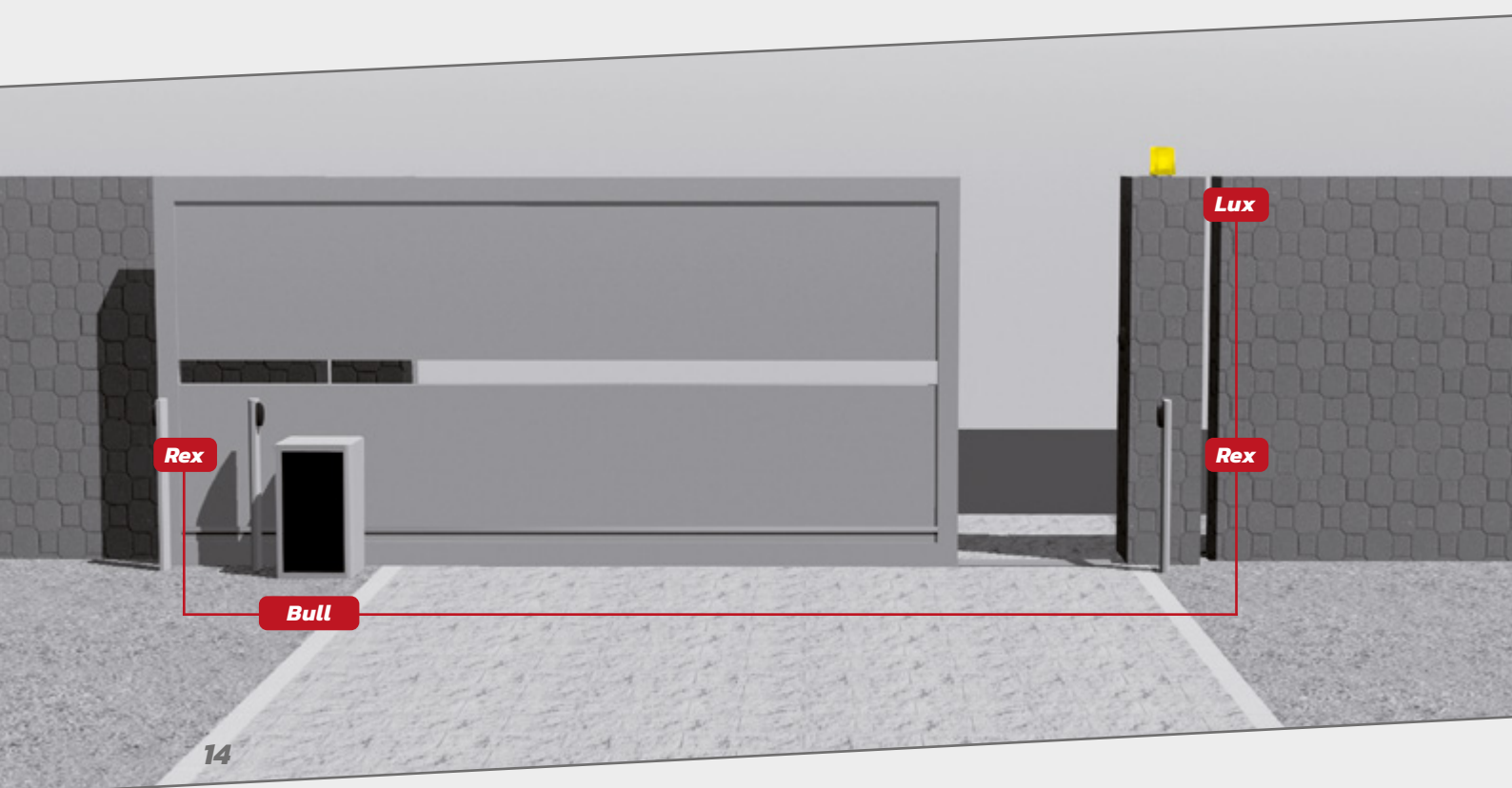



DATI TECNICI / TECHNICAL DATA	<b>Bull 230</b>	<b>Bull 110</b>	<b>Bull 380</b>
ALIMENTAZIONE / POWER SUPPLY	230 v 50/60 Hz	110 v 50/60 Hz	380 v 50/60 Hz
TEMPERATURA DI ESERCIZIO / OPERATING TEMPERATURE	-20° +55°	-20° +55°	-20° +55°
POTENZA MOTORE / POWER MOTOR	650 w	700 w	950 w
CONDENSATORE / CAPACITOR	25 µF	80 µF	-
PESO MASSIMO ANTA / MAX LEAF WEIGHT	2000 KG	2000 KG	2500 KG
GIRI MOTORE / ENGINE REVOLUTIONS	1400	1400	1400
PIGNONE / PINION	Mod4 Z16	Mod4 Z16	Mod4 Z16
VELOCITÀ APERTURA E CHIUSURA / OPENING TIME	9,6 M/MIN	9,6 M/MIN	9,6 M/MIN
PESO MOTORE / WEIGHT	20 KG	20 KG	20 KG
GRANDO DI PROTEZIONE / PROTECTION'S DEGREE	IP44	IP44	IP44
LUBRIFICAZIONE / LUBRIFICATION	OIL	OIL	OIL
FREQUENZA UTILIZZO / FRÉQUENCE	INTENSIVE	INTENSIVE	INTENSIVE

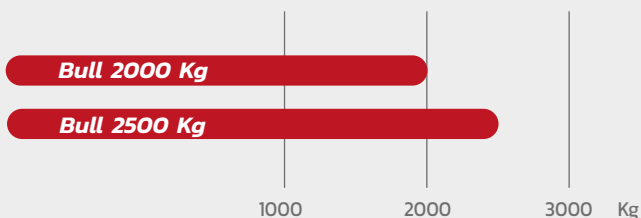

- Peso massimo dei cancelli azionabili dai motori della gamma **Bull**.
- Maximum capacity of **Bull** operators.
- Peso máximo de las puertas por los motores de la gama **Bull**.
- Poids maximum des portails entraînés par les opérateurs **Bull**.

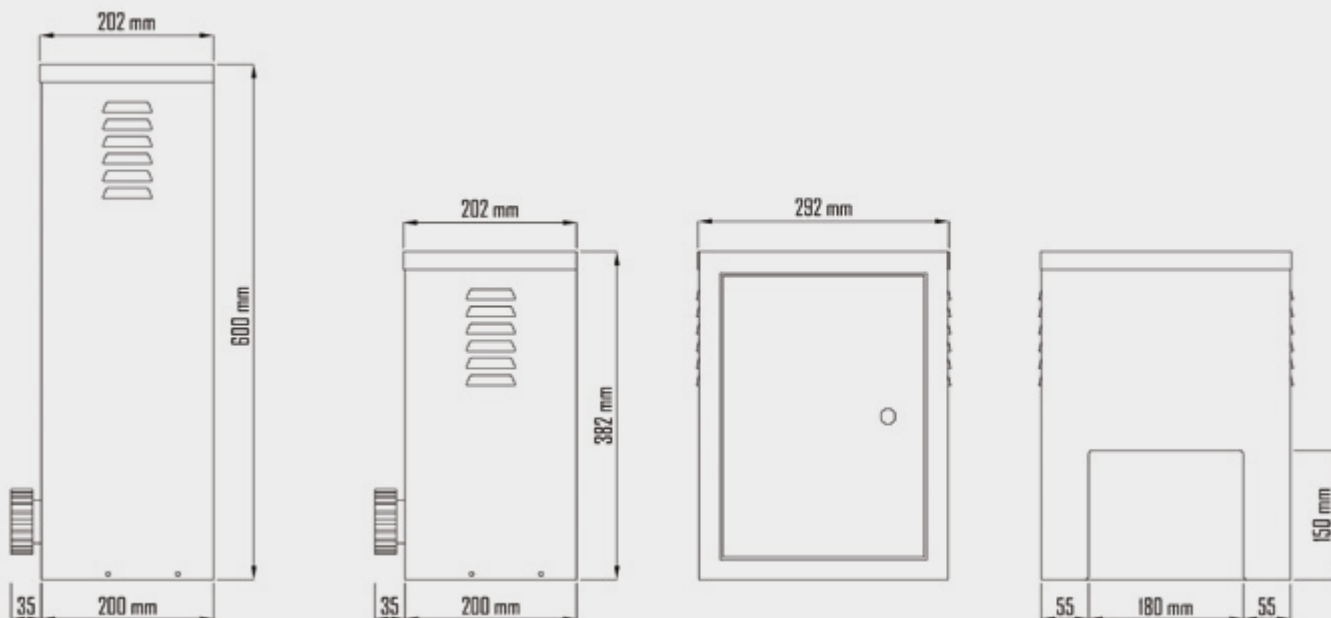

**Bull 2500 Kg**  
380 Vac

**Bull 2000 Kg**  
110-230 Vac

# Bull



**Bull 2000 110V-230V / 2000 Kg**

**Cod. 1501000 / € 900,00**

**Bull 2500 380V (three-phase) / 2500 Kg**

**Cod. 1701000 / € 1.200,00**

**Bull 2500 380V INVERTER (three-phase) / 2500 Kg**

**Cod. 1701099 / € 1.387,00**

- Motoriduttore 110/230/380Vac con riduzione in bagno d'olio
- Centrale METRA Force 380

- Gear motor 110/230/380Vac with gearing in oil bath
- Control unit METRA Force 380

- Motoreductor 110/230/380Vac con reductor en baño de aceite
- Controladora METRA Force 380

- Opérateur 110/230/380Vac avec engranages en bain d'huile
- Centrale de commande METRA Force 380

## Kit small

**Bull 2000 110V-230V / 2000 Kg**

**Cod. 1501200 / € 962,00**

**Bull 2500 380V (three-phase) / 2500 Kg**

**Cod. 1701200 / € 1.262,00**

**Bull 2500 380V INVERTER (three-phase) / 2500 Kg**

**Cod. 1701299 / € 1.449,50**

- Motoriduttore 110/230/380Vac con rifusione in bagno d'olio
- Centrale METRA Force 380
- 2 telecomandi STAR2

- Gear motor 110/230/380Vac with gearing in oil bath
- Control unit METRA Force 380
- 2 remote controls STAR2

- Motoreductor 110/230/380Vac con reductor en baño de aceite
- Controladora METRA Force 380
- 2 mandos STAR2

- Opérateur 110/230/380Vac avec engranages en bain d'huile
- Centrale de commande METRA Force 380
- 2 télécommandes STAR2

## Kit top

**Bull 2000 110V-230V / 2000 Kg**

**Cod. 1501211 / € 1.067,00**

**Bull 2500 380V (three-phase) / 2500 Kg**

**Cod. 1701211 / € 1.367,00**

**Bull 2500 380V INVERTER (three-phase) / 2500 Kg**

**Cod. 1701399 / € 1.554,50**

- Motoriduttore 110/230/380Vac con rifusione in bagno d'olio
- Centrale METRA Force 380
- 2 telecomandi STAR2
- 1 REX20 fotocellule
- 1 LUX lampeggiante

- Gear motor 110/230/380Vac with gearing in oil bath
- Control unit METRA Force 380
- 2 remote controls STAR2
- 1 REX20 photocells
- 1 LUX flashing light

- Motoreductor 110/230/380Vac con reductor en baño de aceite
- Controladora METRA Force 380
- 2 mandos STAR2
- 1 REX20 fotocélulas
- 1 LUX lámpara

- Opérateur 110/230/380Vac avec engranages en bain d'huile
- Centrale de commande METRA Force 380
- 2 télécommandes STAR2
- 1 REX20 photocellule
- 1 LUX lampe clignotante



***Automations that integrate with  
each person's habits, respecting  
and safeguarding the environment***

*Automazioni che si integrano con le abitudini  
di ogni persona, con rispetto e salvaguardia  
dell'ambiente*

*Automatización que se integra con los  
hábitos de cada persona, respetando y  
salvaguardando el medio ambiente*

*Automatismes qui s'intègrent avec les  
habitudes de chaque personne, dans le respect  
et la sauvegarde de l'environnement*

# Mega5

400 Vac  
5000 Kg



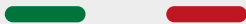

100% Produced in Italy



 **Mega5** è un motoriduttore elettromeccanico trifase per cancelli scorrevoli ad uso industriale per aperture fino a 5000 kg

 **Mega5** is an electromechanical three-phase gear motor for sliding gates projected properly for industrial applications opens gates up to 5000 kg

 **Mega5** es un motoreductor electromecánico trifásico para puertas correderas de uso industrial abre puertas correderas hasta lo 5000 kg

 **Mega5** est un motoréducteur electromécanique triphasé pour portails coulissants à usage industriel. Il ouvre portails coulissants jusqu'à 5000 kg

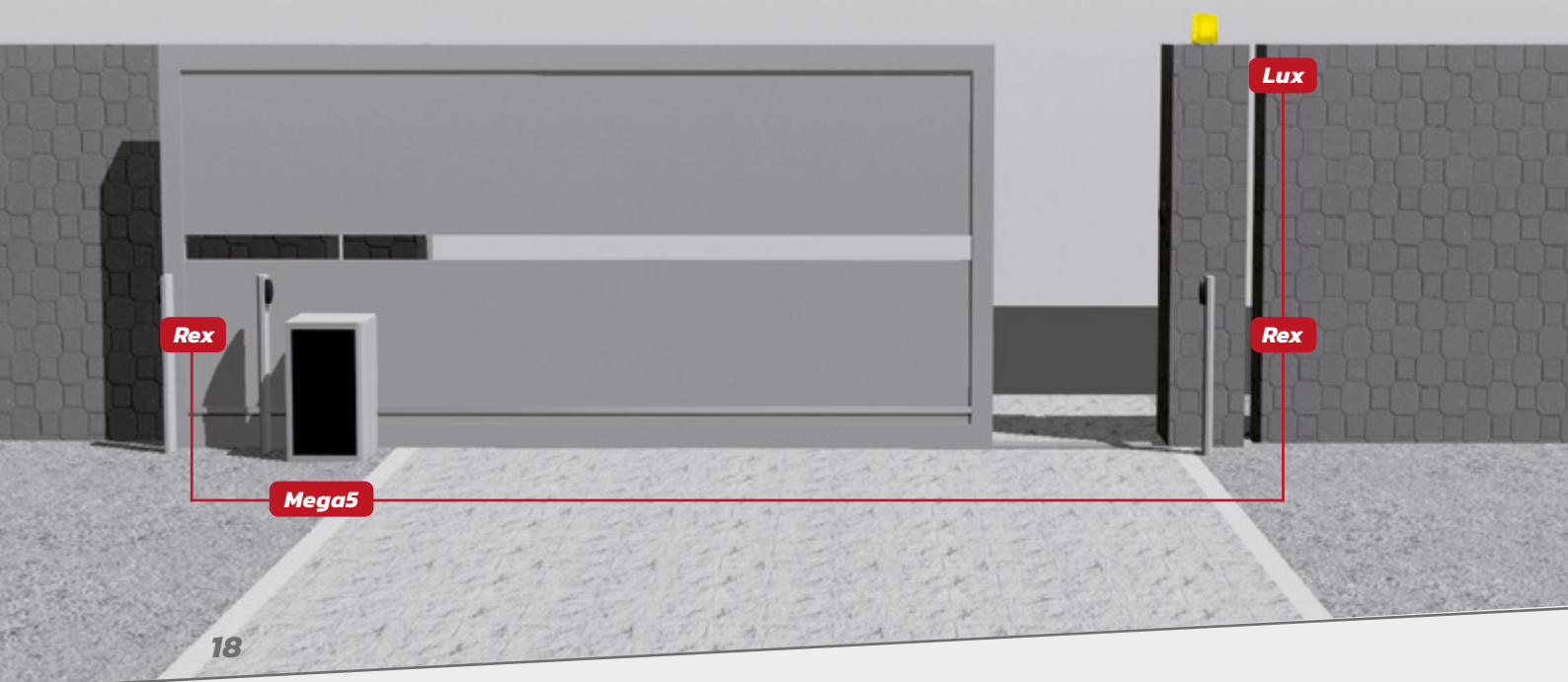



**DATI TECNICI / TECHNICAL DATA**
**Mega5 Inverter**
**Mega5**

ALIMENTAZIONE GENERALE / MAIN POWER SUPPLY	110/230 Vac	400 Vac
ALIMENTAZIONE MOTORE / POWER SUPPLY	400 Vac 50/60 Hz	400 Vac 50/60 Hz
TEMPERATURA DI ESERCIZIO / OPERATING TEMPERATURE	-20° +75°	-20° +75°
PESO MASSIMO CANCELLO / MAXIMUM GATE WEIGHT	5000 KG	5000 KG
POTENZA / RATED POWER	750 W	750 W
PIGNONE / PINION	Z20	Z20
GRADO IP / IP	54	54
PESO MOTORE / WEIGHT	40 KG	40 KG
LUBRIFICAZIONE / LUBRIFICATION	Olio / Oil	Olio / Oil

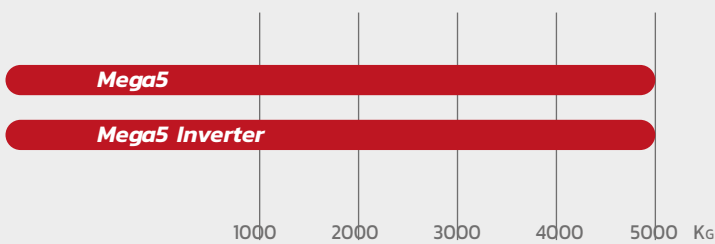

- Peso massimo dei cancelli azionabili dai motori della gamma **Mega5**.
- Maximum capacity of **Mega5** operators..
- Peso máximo de las puertas por los motores de la gama **Mega5**.
- Poids maximum des portails entraînés par les opérateurs **Mega5**.

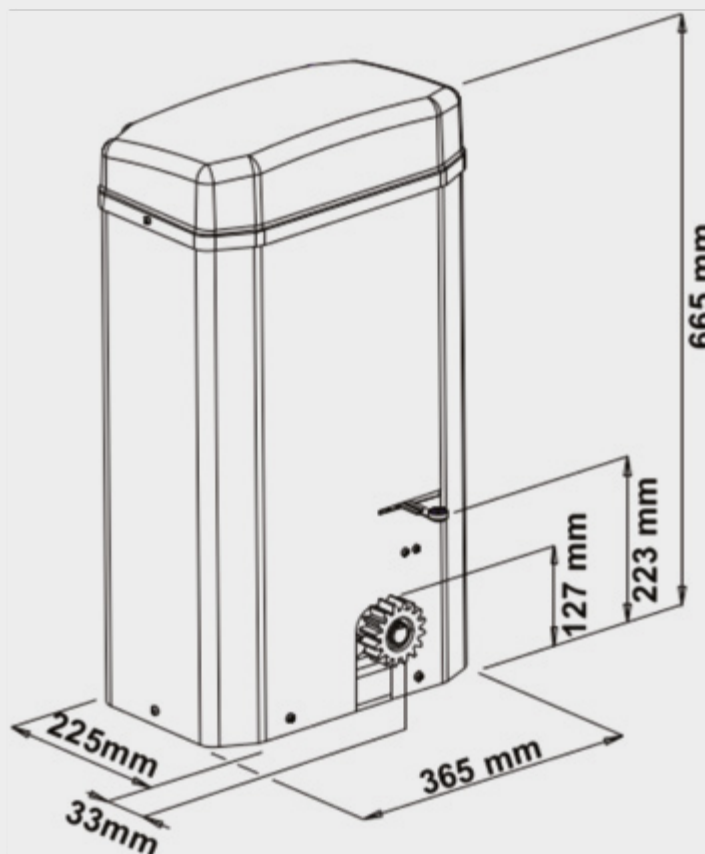

# Mega5



**Mega5 / 5.000kg**

**Cod. 1801000 / € 2.600,00**



**Mega5 inverter / 5.000kg**

**Cod. 1801099 / € 2.850,00**

- Motoriduttore portata 5.000 Kg
- Centralina FORCE400/ FORCE400I
- Elettrofreno
- Sblocco meccanico
- Motore 400V trifase

- Gear motor up to 5.000 kg capacity
- control unit FORCE400/ FORCE400I
- Electrobrake
- Mechanical release
- Three-phase 400V motor

- Motoreductor portata de 5.000 kg
- Controladora FORCE400/ FORCE400I
- Electrofreno
- Desbloqueo mecánico
- Motor 400V trifásico

- Opérateur jusqu' à 5.000 kg
- Centrale de commande FORCE400/FORCE400I
- Électrofrein
- Déverrouillage mécanique
- Moteur 400V triphasé

# Accessories



## CN / 800kg

**Cod. 9800000 / € 15,00**

Cremagliera in nylon portata 800kg, confezione 10x1 m

Nylon rack for max 800kg gate, pack of 10x1 m

Cremallera en nylon capacidad 800kg, confección 10x1 m

Cremaillère en nylon jusqu' à 800 kg, pack de 10x1 m

## C12 / 30 × 12 × 1000

**Cod. 9820000 / € 20,00**

Cremagliera in metallo, confezione 4x1 m

Iron rack, pack of 4x1 m

Cremallera en metal, confezione 4x1 m

Cremaillère en fer, pack de 4x1 m

## C22 / 22 × 22 × 2000

**Cod. 9830000 / € 22,00**

Cremagliera in metallo, min. 10m

Iron rack, min. 10m

Cremallera en metal, min. 10m

Cremaillère en fer, min. 10m

## Metra 230 / 230Vac

**Cod. 8010000 / € 190,00**

Centrale con rallentamenti in apertura/chiusura regolabili, ricevente integrata

Control unit with adjustable slowing down feature on opening/closing, built-in receiver

Cuadro de maniobra con ralentizaciones en apertura/cierre, receptor incorporado

Centrale de commande avec ralentissements ouverture/fermeture, récepteur incorporé

## Metra B 230 / 230Vac

**Cod. 8011000 / € 190,00**

Centrale con rallentamenti in apertura/chiusura regolabili, ricevente integrata. Per motore Bull 230v

Control unit with adjustable slowing down feature on opening/closing, built-in receiver. For Bull 230v operator

Cuadro de maniobra con ralentizaciones en apertura/cierre, receptor incorporado. Por motoreductor Bull 230v

Centrale de commande avec ralentissements ouverture/fermeture, récepteur incorporé. Pour opérateur Bull 230v

## Metra 24 / 24Vdc

**Cod. 8015000 / € 198,00**

Centrale con rallentamenti in apertura/chiusura, ricevente e carica batterie integrati con memoria per 254 telecomandi

Control unit with adjustable slowing down feature on opening/closing, built-in receiver & battery charger with memory up to 254 remotes

Cuadro de maniobra con ralentizaciones en apertura/cierre, receptor y cargabaterías con memoria de 254 mandos

Centrale de commande avec ralentissements ouverture/fermeture, récepteur et chargeur de batterie - mémoire jusqu' à 254 emetteurs

## INVER23 / 800kg

**Cod. 8017000 / € 285,00**

Centrale elettronica 110/230Vac per scorrevoli con tecnologia inverter

110/230vac electronic control unit for sliding automation with inverter

Centrale électronique 110/230Vac pour aut. coulissants avec inverter

Cuadro de maniobra 110/230Vac para correderas con inverter

## FORCE 400 / 400Vac

**Cod. 8018000 / € 340,00**

Centrale elettronica 400Vac a microprocessore per automazioni scorrevoli a motori trifase

Electronic control unit 400Vac with microprocessor for three-phase motor sliding gates

Cuadro de maniobra electrónico 400Vac con microprocesor para controlar automatismos trifasicos para puertas correderas

Centrale électronique 400Vac à microprocesseur pour la gestion de portails coulissants avec moteurs à trois phases

## FORCE 400 / 400Vac Inverter

**Cod. 8018500 / € 540,00**

Centrale elettronica 400Vac a microprocessore per automazioni scorrevoli a motori trifase con tecnologia INVERTER

Electronic control unit 400Vac with microprocessor for three-phase motor sliding gates with INVERTER technology

Cuadro de maniobra electrónico 400Vac con microprocesor para controlar automatismos trifasicos para puertas correderas con tecnologia INVERTER

Centrale électronique 400Vac à microprocesseur pour la gestion de portails coulissants avec moteurs à trois phases avec INVERTER technologie

## Kit ENCODER CITY series

**Cod. 9110000 / € 25,00**

Kit ENCODER per serie CITY

Kit ENCODER for CITY series

Kit ENCODER para la serie CITY

Kit ENCODER pour CITY série

## Kit BAT24

**Cod. 8015240 / € 75,00**

Kit batterie: 2 batterie 12Vdc - 1,2A completo di cavi

Back-up battery kit: 2 batteries 12Vdc - 1,2A with wiring

Kit de 2 baterias de respaldo 12Vdc - 1,2A con cables

Kit batteries: 2 batteries 12Vdc - 1,2A avec câbles

# ***Battenti***

***Swing / Batiente / Battant***

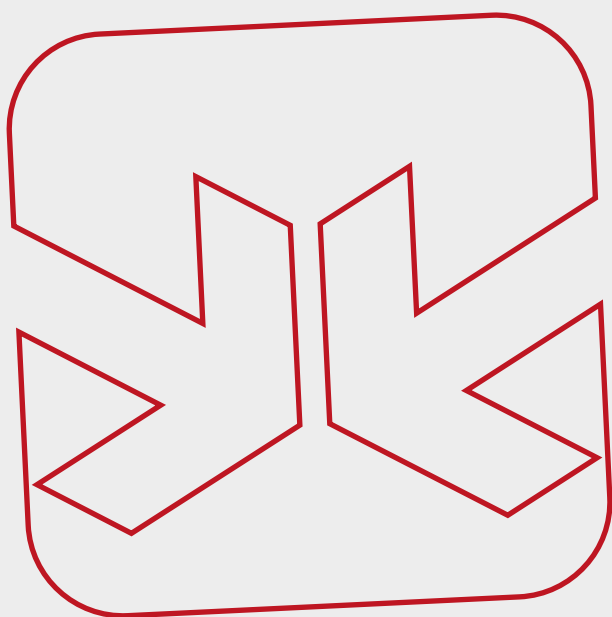

***Simply***

***Idra***

***Sub***

***Arm***

***Logo***

***Accessories***





# Simply

110/230 Vac  
24 Vdc

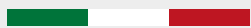
100% Produced in Italy



 **Simply** è un attuatore lineare elettromeccanico per l'apertura di ante battenti residenziali max 4 m / anta

 **Simply** is an electromechanical operator for opening residential swing gate max 4 m / leaf

 **Simply** es un accionador electromecánico para abrir puertas de hojas de uso residencial max 4 m / hoja

 **Simply** est un opérateur linéaire électromécanique pour automatisation de vantaux battants d'un usage résidentiel max 4 m / vantail

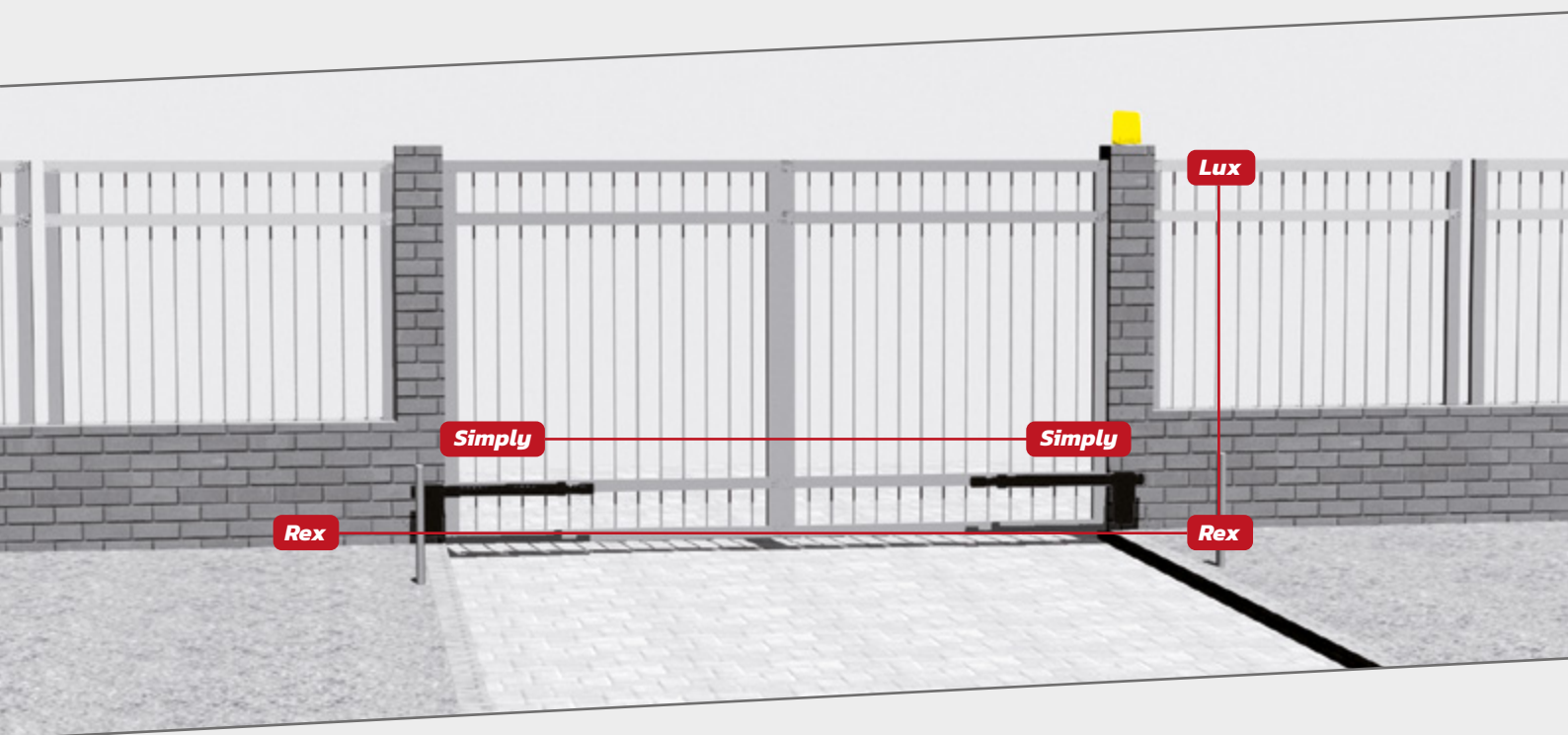

DATI TECNICI / TECHNICAL DATA	<i>Simply 40-SX/DX</i>	<i>Simply 60-SX/DX</i>	<i>Simply 40-24-SX/DX</i>
ALIMENTAZIONE GENERALE / MAIN POWER SUPPLY	110/230 Vac	110/230 Vac	110/230 Vac
ALIMENTAZIONE / MOTOR POWER SUPPLY	110/230 Vac 50/60 Hz	110/230 Vac 50/60 Hz	24 Vdc
TEMPERATURA DI ESERCIZIO / OPERATING TEMPERATURE	-20° +55°	-20° +55°	-20° +55°
DIMENSIONI MAX ANTA / MAXIMUM GATE LENGTH	-	VEDERE GRAFICO / SEE GRAPH	-
SPINTA / TORQUE FORCE	1600 N	1600 N	1400 N
POTENZA / RATED POWER	300 W	320 W	74 W
ASSORBIMENTO / ABSORBED POWER	1,8 A	1,8 A	3,0 A
CONDENSATORE / CAPACITOR	8 µF	8 µF	-
CICLI DI LAVORO / CYCLES PER HOUR	50 %	40 %	80 %
CORSA / USABLE STROKE	400 MM	600 MM	400 MM
GRADO IP / IP	54	54	54
PESO MOTORE / WEIGHT	5,8 KG	6,0 KG	6,0 KG
TEMPO DI APERTURA / OPENING TIME	19 SEC	25 SEC	17 SEC
LUBRIFICAZIONE / LUBRIFICATION	Grasso / Grease	Grasso / Grease	Grasso / Grease

WEIGHT Kg

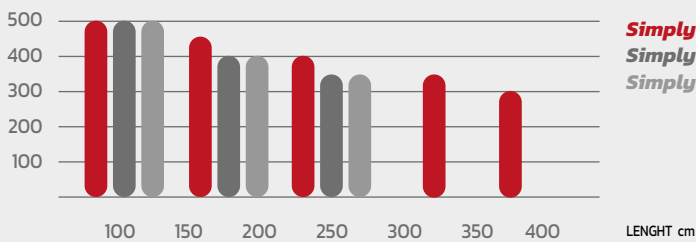

**Simply 60**  
**Simply 40**  
**Simply 40-24**

- Dimensioni massime dell'anta rispetto al peso dei cancelli azionabili della gamma **Simply**.
- Maximum leaf dimensions for **Simply** operators.
- Tamaño máximo de la hoja accionable por los motores de la gama **Simply**.
- Dimensions maximum du vantail pour les opérateurs **Simply**.

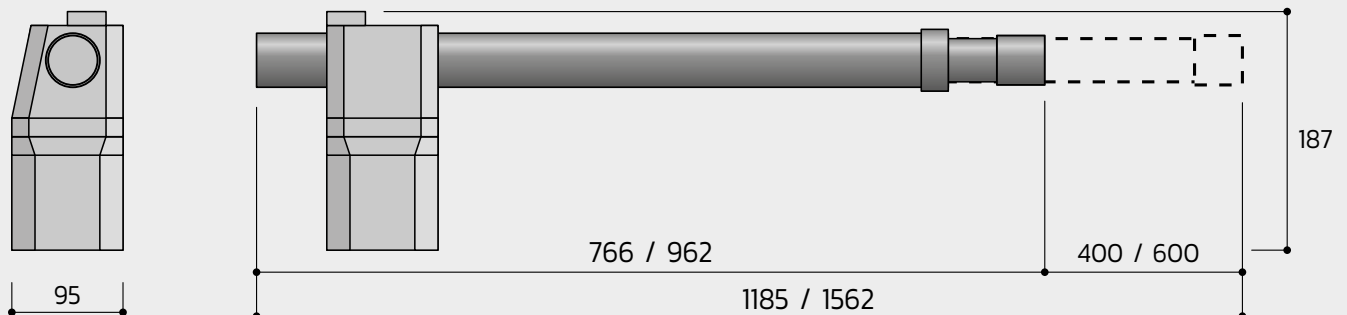

# Simply



**Simply 40 / 230Vac - max 200cm**

**Cod. 2000000 / € 275,00**

**Simply 60 / 230Vac - max 400cm**

**Cod. 2050000 / € 300,00**

**Simply 24 / 24Vdc - max 200cm**

**Cod. 2240000 / € 300,00**

Attuatore elettromeccanico  
230Vac / 24Vdc

Electro-mechanical operator  
230Vac / 24Vdc

Operador electromecanico  
230Vac / 24Vdc

Opérateur électromécanique  
230Vac / 24Vdc

## Kit small

**Simply 40 / Max 200cm**

**Cod. 2001200 / € 612,00**

**Simply 60 / Max 400cm**

**Cod. 2051200 / € 652,00**

**Simply 24 / Max 200cm**

**Cod. 2241200 / € 744,00**

- 2 attuatori 230Vac
- 1 centrale CLIMA230 / CLIMA24
- 2 telecomandi STAR2
- Kit ancoraggio

- 2 operators 230Vac
- 1 central unit CLIMA230 / CLIMA24
- 2 remote controls STAR2
- Mounting kit

- 2 operadores 230Vac
- 1 controladora CLIMA230 / CLIMA24
- 2 mandos STAR2
- Kit de anclajes

- 2 opérateurs 230Vac
- 1 centrale de commande CLIMA230 / CLIMA24
- 2 télécommandes STAR2
- Kit de montage

## Kit top

**Simply 40 / Max 200cm**

**Cod. 2001211 / € 656,00**

**Simply 60 / Max 400cm**

**Cod. 2051211 / € 696,00**

**Simply 24 / Max 200cm**

**Cod. 2241211 / € 788,00**

- 2 attuatori 230Vac
- 1 centrale CLIMA230 / CLIMA24
- 2 telecomandi STAR2
- REX20 fotocellule
- LUX lampeggiante
- Kit ancoraggio

- 2 operators 230Vac
- 1 central unit CLIMA230 / CLIMA24
- 2 remote controls STAR2
- REX20 photocells
- LUX flashing light
- Mounting kit

- 2 operadores 230Vac
- 1 controladora CLIMA230 / CLIMA24
- 2 mandos STAR2
- REX20 fotocélulas
- LUX lámpara
- Kit de anclajes

- 2 opérateurs 230Vac
- 1 centrale de commande CLIMA230 / CLIMA24
- 2 télécommandes STAR2
- REX20 photocellules
- LUX lampe clignotante
- Kit de montage

# Idra

110-230 Vac

100% Produced in Italy

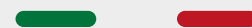

 **Idra** è un operatore idraulico per cancelli ad ante battenti

 **Idra** is an hydraulic operator for swing gates



 **Idra** es un operador hidráulico para hojas batientes

 **Idra** est un opérateur hydraulique pour portails battants

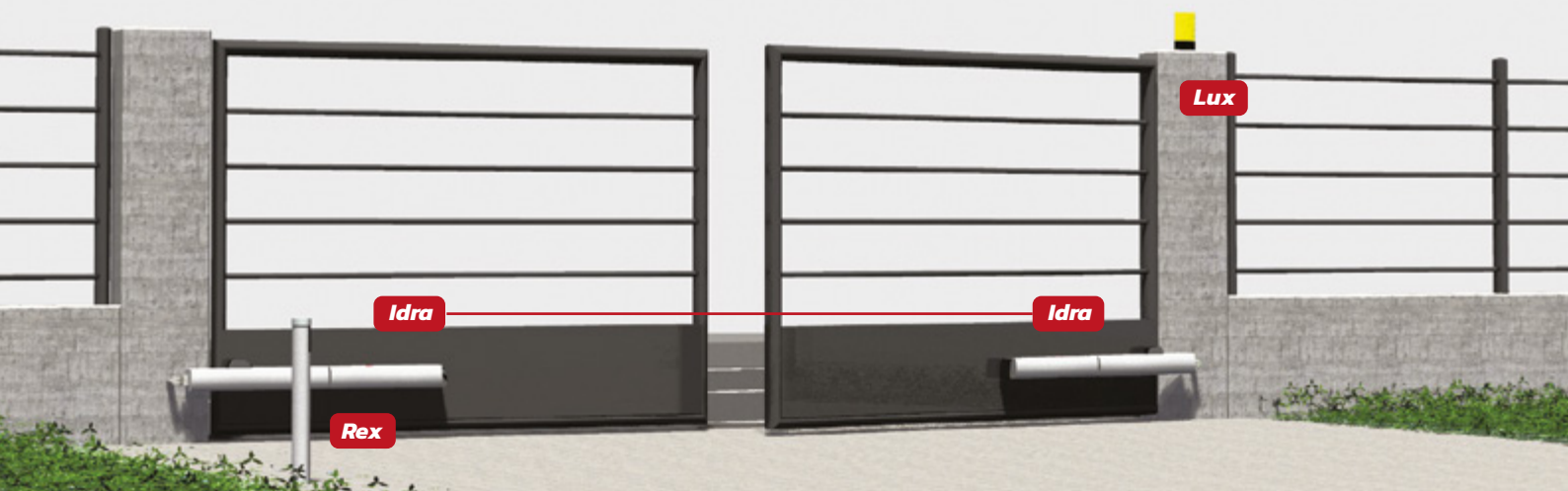



**DATI TECNICI / TECHNICAL DATA**

	<i>Idra 270</i>	<i>Idra 390</i>
ALIMENTAZIONE GENERALE / MAIN POWER SUPPLY	230 Vac	230 Vac
ALIMENTAZIONE MOTORE / POWER SUPPLY	230 Vac	230 Vac
TEMPERATURA DI ESERCIZIO / OPERATING TEMPERATURE	-25° +70°	-25° +70°
DIMENSIONI MAX ANTA / MAXIMUM GATE LENGTH	VEDERE GRAFICO / SEE GRAPH	VEDERE GRAFICO / SEE GRAPH
SPINTA / TORQUE FORCE	1850 N	2240 N
POTENZA / RATED POWER	250 W	350 W
ASSORBIMENTO / ABSORBED POWER	1,0 A	1,9 A
CONDENSATORE / CAPACITOR	8 µF	10 µF
CICLI DI LAVORO / DUTY	90 %	90 %
GRADO IP / IP	55	55
LUBRIFICAZIONE / LUBRIFICATION	Olio / Oil	Olio / Oil

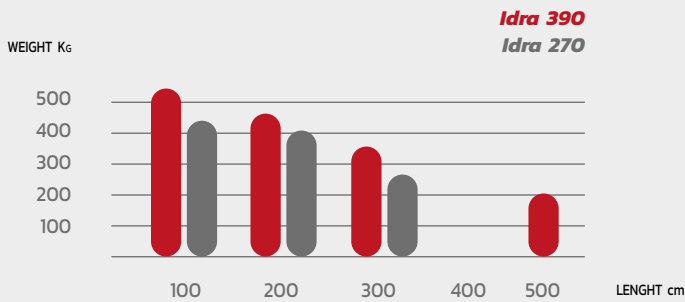

- Dimensioni massime dell'anta rispetto al peso dei cancelli azionabili della gamma **Idra**.
- Maximum leaf dimensions for **Idra** operators.
- Tamaño máximo de la hoja accionable por los motores de la gama **Idra**.
- Dimensions maximum du vantail pour les opérateurs **Idra**.

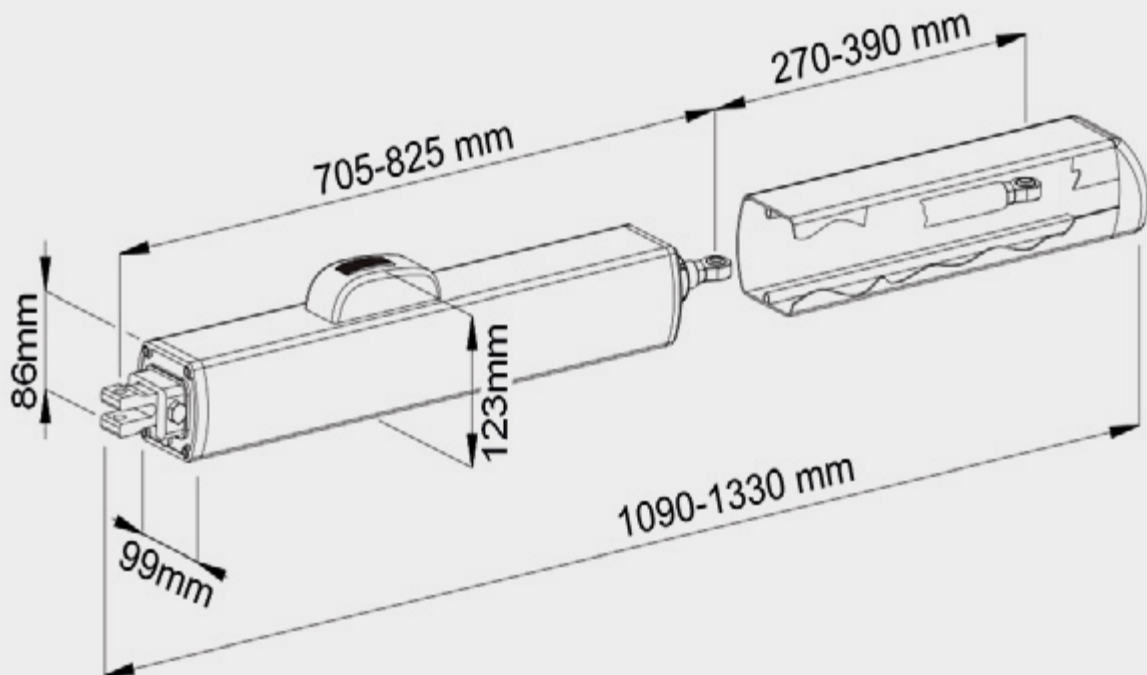

# Idra



**Idra 270 / Max 300cm**

**Cod. 2300000 / € 583,00**

**Idra 390 / Max 500cm**

**Cod. 2350000 / € 620,00**

Motoriduttore idraulico 230Vac

Hydraulic operator 230Vac

Motoreductor hidraulico 230Vac

Opérateur hydraulique 230Vac

## Kit small

**Idra 270 / Max 300cm**

**Cod. 2300002 / € 1.448,00**

**Idra 390 / Max 500cm**

**Cod. 2350002 / € 1.522,00**

- 2 attuatori 230Vac
- 1 centrale CLIMA230
- 2 telecomandi STAR2

- 2 operators 230Vac
- 1 central unit CLIMA230
- 2 remote controls STAR2

- 2 operadores 230Vac
- 1 controladora CLIMA230
- 2 mandos STAR2

- 2 opérateurs 230Vac
- 1 centrale de commande CLIMA230
- 2 télécommandes STAR2

## Kit top

**Idra 270 / Max 300cm**

**Cod. 2300001 / € 1.553,00**

**Idra 390 / Max 500cm**

**Cod. 2350001 / € 1.627,00**

- 2 attuatori 230Vac
- 1 centrale CLIMA230
- 2 telecomandi STAR2
- 1 REX20 fotocellule
- 1 LUX lampeggiante

- 2 operators 230Vac
- 1 central unit CLIMA230
- 2 remote controls STAR2
- 1 REX20 photocells
- 1 LUX flashing light

- 2 operadores 230Vac
- 1 controladora CLIMA230
- 2 mandos STAR2
- 1 REX20 fotocélulas
- 1 LUX làmpara

- 2 opérateurs 230Vac
- 1 centrale de commande CLIMA230
- 2 télécommandes STAR2
- 1 REX20 photocellules
- 1 LUX lampe clignotante







# Sub 110/230 Vac 24 Vdc

100% Produced in Italy



 **Sub** è un operatore elettromeccanico interrato per cancelli ad ante battenti max 3,5m / anta

 **Sub** is an underground electromechanical operator for swing gates max 3,5m / leaf

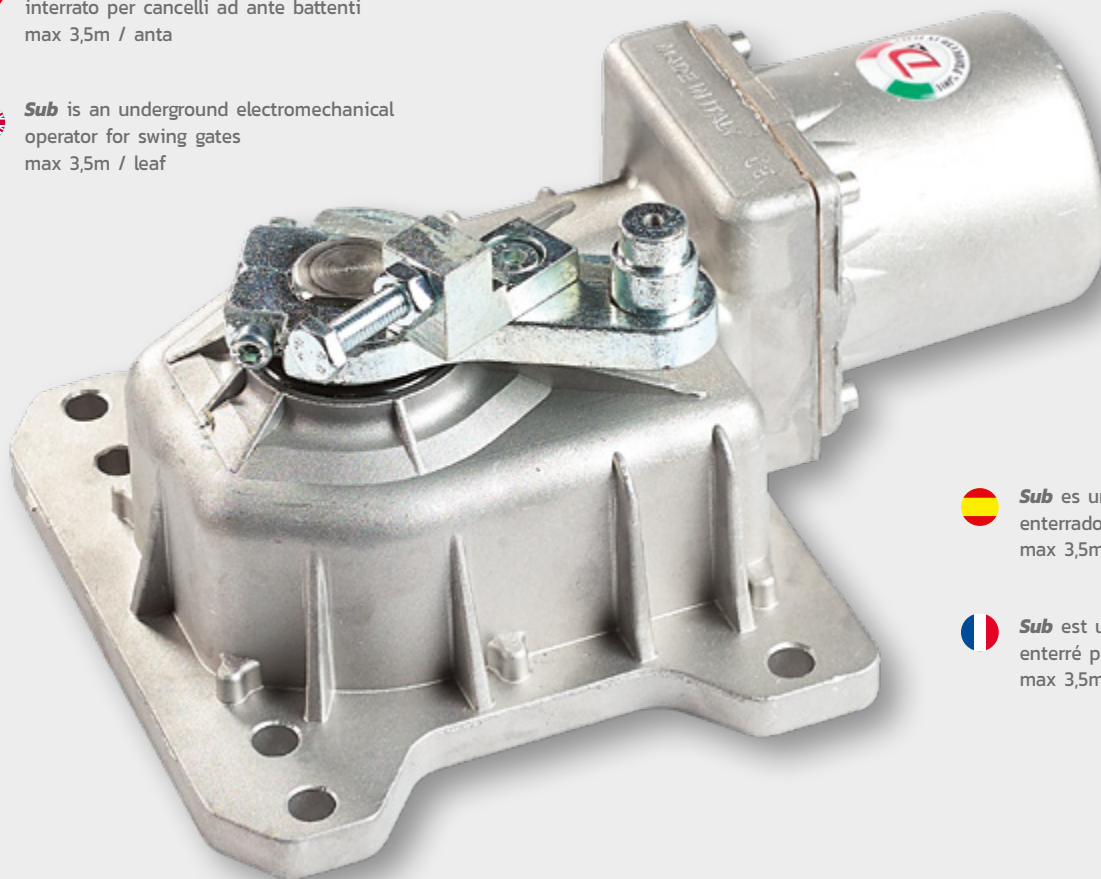

 **Sub** es un operador electromecánico enterrado para puertas de hojas max 3,5m / hoja

 **Sub** est un opérateur électromécanique enterré pour portails battants max 3,5m / vantail

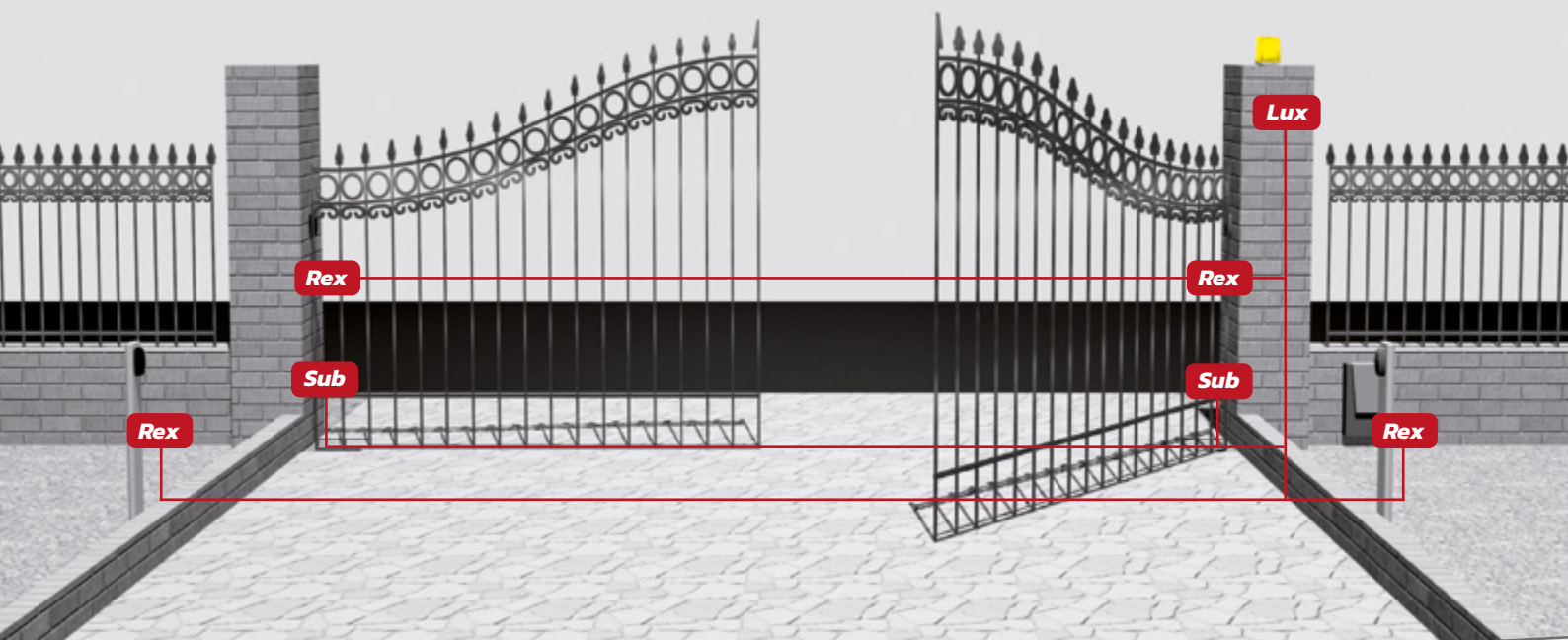

**DATI TECNICI / TECHNICAL DATA**
**Sub**
**Sub 24**

ALIMENTAZIONE GENERALE / MAIN POWER SUPPLY	110/230 Vac	110/230 Vac
ALIMENTAZIONE / MOTOR POWER SUPPLY	230 Vac 50/60 Hz	24 Vdc
TEMPERATURA DI ESERCIZIO / OPERATING TEMPERATURE	-20° +55°	-20° +55°
DIMENSIONI MAX ANTA / MAXIMUM GATE LENGTH	VEDERE GRAFICO / SEE GRAPH	3,5 M
SPINTA / TORQUE FORCE	250 NM	250 NM
POTENZA / RATED POWER	280 W	50 W
ASSORBIMENTO / ABSORBED POWER	1,4 A	3 A
CONDENSATORE / CAPACITOR	12,5 µF	
RPM / RPM	1400	1800
GRADO IP / IP	67	67
PESO MOTORE / WEIGHT	10 KG	10 KG
LUBRIFICAZIONE / LUBRIFICATION	Grasso / Grease	Grasso / Grease

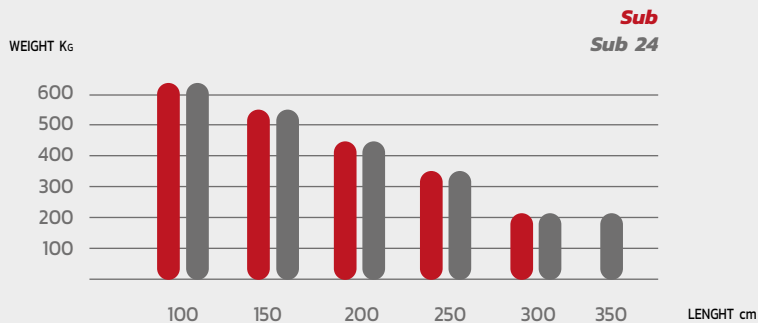

- Dimensioni massime dell'anta rispetto al peso dei cancelli azionabili della gamma **Sub**.
- Maximum leaf dimensions for **Sub** operators.
- Tamaño máximo de la hoja accionable por los motores de la gama **Sub**.
- Dimensions maximum du vantail pour les opérateurs **Sub**.

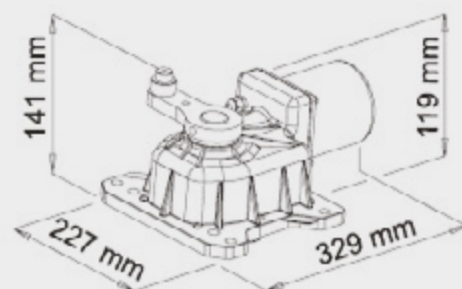
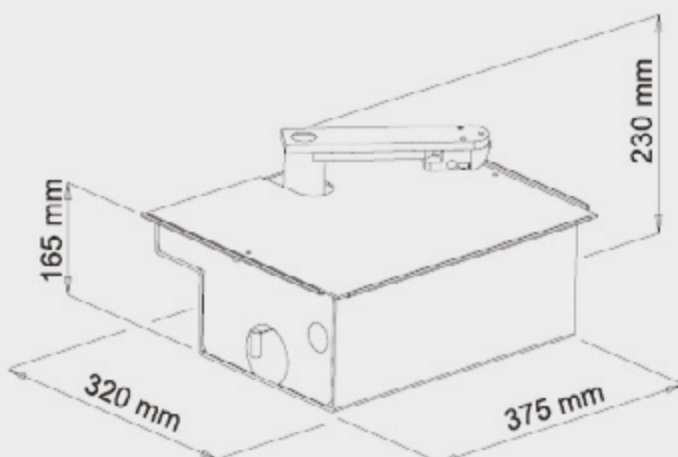



# Sub



**Sub / Max 300cm**

**Cod. 2800000 / € 375,00**

**Sub 24 / Max 350cm**

**Cod. 2824000 / € 425,00**

Motoriduttore interrato 1400 rpm con leva di trasmissione

Underground gear motor 1400 rpm with transmission lever

Motoreductor enterrado 1400 rpm con palanca de transmisión

Opérateur enterré 1400 rpm avec bielle de transmission

## Kit small

**Sub / Max 300cm**

**Cod. 2801200 / € 1.363,00**

**Sub 24 / Max 350cm**

**Cod. 2824120 / € 1.675,00**

- 2 attuatori 230Vac / 24Vdc
- 1 centrale CLIMA230 / CLIMA24
- 2 telecomandi STAR2
- 2 Boxplus

- 2 operators 230Vac / 24Vdc
- 1 central unit CLIMA230 / CLIMA24
- 2 remote controls STAR2
- 2 Boxplus

- 2 operadores 230Vac / 24Vdc
- 1 controladora CLIMA230 / CLIMA24
- 2 mandos STAR2
- 2 Boxplus

- 2 opérateurs 230Vac / 24Vdc
- 1 centrale de commande CLIMA230 / CLIMA24
- 2 télécommandes STAR2
- 2 Boxplus

## Kit top

**Sub / Max 300cm**

**Cod. 2801211 / € 1.413,00**

**Sub 24 / Max 350cm**

**Cod. 2821211 / € 1.730,00**

- 2 attuatori 230Vac / 24Vdc
- 1 centrale CLIMA230 / CLIMA24
- 2 telecomandi STAR2
- 1 REX20 fotocellule
- 1 LUX lampeggiante
- 2 Boxplus

- 2 operators 230Vac / 24Vdc
- 1 central unit CLIMA230 / CLIMA24
- 2 remote controls STAR2
- 1 REX20 photocells
- 1 LUX flashing light
- 2 Boxplus

- 2 operadores 230Vac / 24Vdc
- 1 controladora CLIMA230 / CLIMA24
- 2 mandos STAR2
- 1 REX20 fotocélulas
- 1 LUX lámpara
- 2 Boxplus

- 2 opérateurs 230Vac / 24Vdc
- 1 centrale de commande CLIMA230 / CLIMA24
- 2 télécommandes STAR2
- 1 REX20 photocellules
- 1 LUX lampe clignotante
- 2 Boxplus

## Parts

**Box PLUS**

**Cod. 9288000 / € 240,00**

Cassa zincata dotata di leva sblocco, finecorsa di chiusura di serie

Galvanized steel box with lever release, mechanical stopper on closing included

Caja galvanizada con palanca de desbloqueo, tope mecánico en cierre incluido

Caisson zingué avec levier de déverrouillage, fin de courses mécaniques en fermeture

**PLUS 180**

**Cod. 9285000 / € 140,00**

Kit per apertura fino a 180°

Kit for opening up to 180°

Kit para aperturas hasta 180°

Kit pour ouverture jusqu' à 180°

**Kit FM**

**Cod. 9310010 / € 45,00**

Coppia finecorsa meccanici

Pair of mechanical limit switches

Finales de carrera mecánicas

Fins de course mécaniques

**Keyplus**

**Cod. 9287000 / € 220,00**

Staffa con serratura con chiave personalizzata

Lockable bracket with personalized key

Soporte bloqueable con llave personalizada

Support verrouillable avec clé personnalisée



***Technologies designed for people  
to ensure safety and reliability***

*Tecnologie pensate per le persone, per  
garantire sicurezza e affidabilità*

*Tecnologías diseñadas para las personas,  
para garantizar seguridad y fiabilidad*

*Technologies conçues pour les gens, qui  
assurent sécurité et fiabilité*

# Arm 230 Vac

100% Produced in Italy



 **Arm** è un motoriduttore elettromeccanico con braccio articolato per cancelli battenti di medie e grandi dimensioni  
max 4 m / anta

 **Arm** is an electromechanical actuator with articulated arm for medium and big size gates  
max 4 m / leaf

 **Arm** es un motoreductor electromecánico de brazo articulado para puertas de hojas de medias y grandes dimensiones  
max 4 m / hoja

 **Arm** est un opérateur électromécanique avec bras articulé pour portails battants de moyennes et grandes dimensions  
max 4 m / vantail

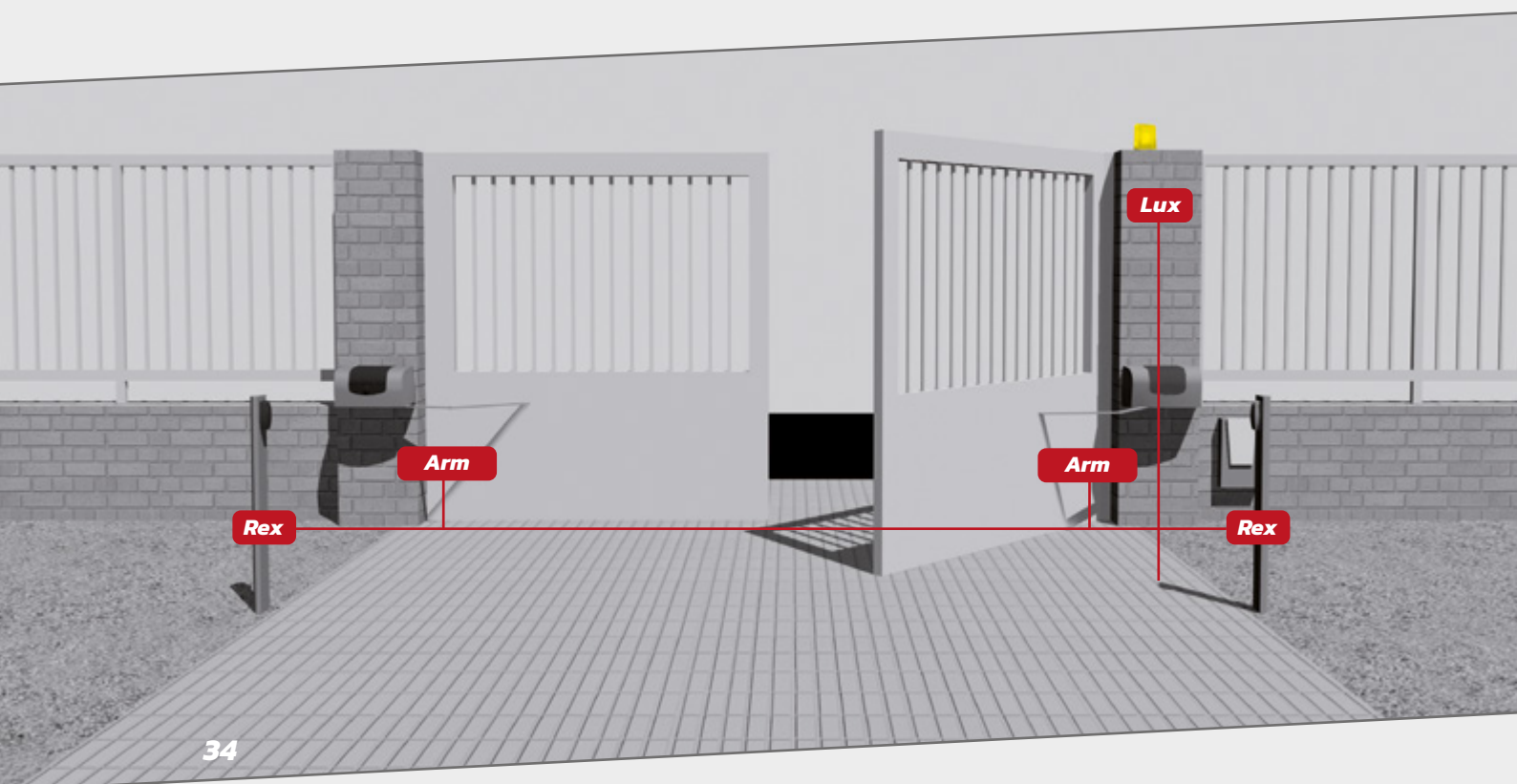

**DATI TECNICI / TECHNICAL DATA**
**Arm**

ALIMENTAZIONE GENERALE / MAIN POWER SUPPLY	230 Vac 50/60 Hz
ALIMENTAZIONE / MOTOR POWER SUPPLY	230 Vac 50/60 Hz
TEMPERATURA DI ESERCIZIO / OPERATING TEMPERATURE	-25° +70°
DIMENSIONI MAX ANTA / MAXIMUM GATE LENGTH	VEDERE GRAFICO / SEE GRAPH
SPINTA / TORQUE FORCE	480 NM
POTENZA / RATED POWER	250 W
ASSORBIMENTO / ABSORBED POWER	1,0 A
CONDENSATORE / CAPACITOR	10 µF
CICLI DI LAVORO / DUTY	50 %
GIRI DI USCITA / OUTPUT REVOLUTIONS	1,8 G/MIN
GRADO IP / IP	54
PESO MOTORE / WEIGHT	14 KG
LUBRIFICAZIONE / LUBRIFICATION	Grasso / Grease

WEIGHT Kg

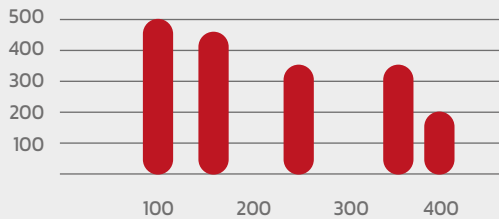
**Arm**

LENGHT cm

- Dimensioni massime dell'anta rispetto al peso dei cancelli azionabili della gamma **Arm**.
- Maximum leaf dimensions for **Arm** operators.
- Tamaño máximo de la hoja accionable por los motores de la gama **Arm**.
- Dimensions maximum du vantail pour les opérateurs **Arm**.

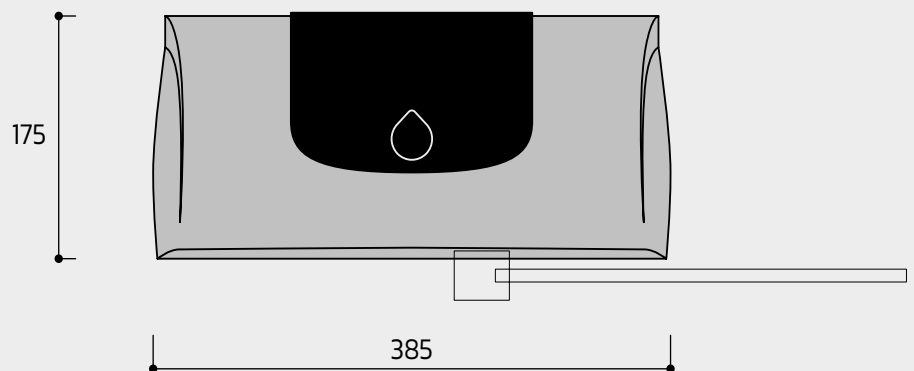
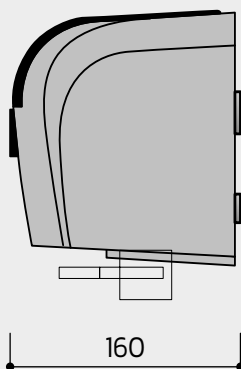

# Arm



## Arm / Max 400cm

**Cod. 2600000 / € 449,00**

Motoriduttore con braccio cod. BD incluso

Operator with arm BD included

Motoreductor con brazo recto BD incluido

Opérateur avec bras droit BD inclus

## Kit small

### Arm / Max 400cm

**Cod. 2601200 / € 1.125,00**

- 2 attuatori 230Vac
- 1 centrale CLIMA230
- 2 telecomandi STAR2
- Kit ancoraggio
- BD

- 2 operators 230Vac
- 1 central unit CLIMA230
- 2 remote controls STAR2
- Mounting kit
- BD

- 2 operadores 230Vac
- 1 controladora CLIMA230
- 2 mandos STAR2
- kit de anclajes
- BD

- 2 opérateurs 230Vac
- 1 centrale de commande CLIMA230
- 2 télécommandes STAR2
- kit de montage
- BD

## Kit top

### Arm / Max 400cm

**Cod. 2601211 / € 1.177,00**

- 2 attuatori 230Vac
- 1 centrale CLIMA230
- 2 telecomandi STAR2
- 1 REX20 fotocellule
- 1 LUX lampeggiante
- kit ancoraggio
- BD

- 2 operators 230Vac
- 1 central unit CLIMA230
- 2 remote controls STAR2
- 1 REX20 photocells
- 1 LUX flashing light
- Mounting kit
- BD

- 2 operadores 230Vac
- 1 controladora CLIMA230
- 2 mandos STAR2
- 1 REX20 fotocélulas
- 1 LUX lámpara
- Kit de anclajes
- BD

- 2 opérateurs 230Vac
- 1 centrale de commande CLIMA230
- 2 télécommandes STAR2
- 1 REX20 photocellules
- 1 LUX lampe clignotante
- Kit de montage
- BD

## Parts

### Bd / 380mm

**Cod. 9058000 / € 82,00**

Braccio dritto completo, anticesoimento, lungo 380mm

Anti-shearing arm, 380mm long

Brazo recto completo, antiplastiamento, lungo 380mm

Bras droit complet, anticisaillement, longueur 380mm





***Automations designed for any environment and culture context, to enhance ideas and diversity***

*Automazioni pensate per ogni contesto ambientale e culturale, per valorizzarne le idee e ogni diversità*

*Ideal para cualquier contexto de entorno y cultura, para mejorar sus ideas y diversidad*

*Automatismes idéaux pour tout contexte environnemental et culturel, pour valoriser idées et diversité*

# Logo 24 Vdc

100% Produced in Italy

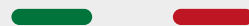

 **Logo** è un motoriduttore elettromeccanico con braccio articolato per cancelli battenti max 2,5 m / anta

 **Logo** is an electromechanical actuator with articulated arm for swing gates max 2,5 m / leaf

 **Logo** es un motoreductor electromecánico de brazo articulado para puertas de hojas de max 2,5 m / hoja

 **Logo** est un opérateur électromécanique avec bras articulé pour portails battants de max 2,5 m / vantail

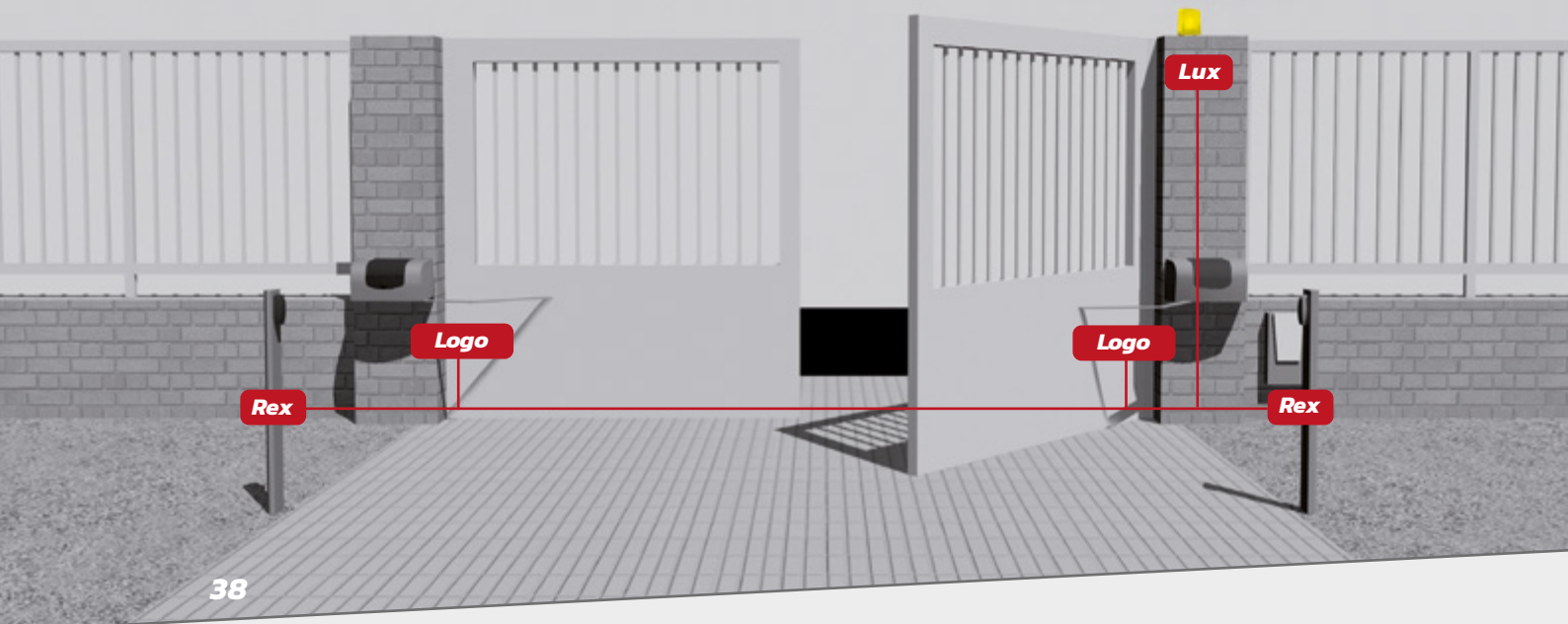

**DATI TECNICI / TECHNICAL DATA**
**Logo**

ALIMENTAZIONE GENERALE / MAIN POWER SUPPLY	110/230 Vac
ALIMENTAZIONE / MOTOR POWER SUPPLY	24 Vdc
TEMPERATURA DI ESERCIZIO / OPERATING TEMPERATURE	-20° +55°
PESO MAX ANTA / MAXIMUM GATE WEIGHT	150 KG
DIMENSIONI MAX ANTA / MAXIMUM GATE LENGTH	2,5 M
POTENZA / RATED POWER	50 W
ASSORBIMENTO / ABSORBED POWER	3 A
GIRI MOTORE / ENGINE RPM	1800 RPM
RUMOROSITÀ / NOISE LEVEL	< 30 DBA
PESO MOTORE / WEIGHT	9,5 KG
GRADO IP / IP	44

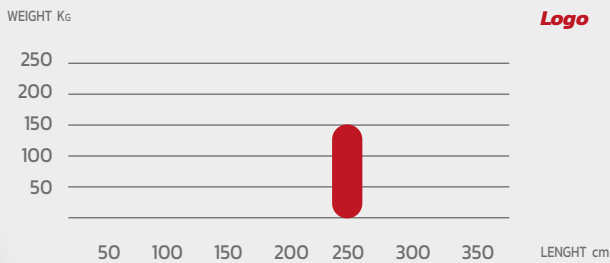

- Dimensioni massime dell'anta rispetto al peso dei cancelli azionabili della gamma **Logo**.
- Maximum leaf dimensions for **Logo** operators.
- Tamaño máximo de la hoja accionable por los motores de la gama **Logo**.
- Dimensions maximum du vantail pour les opérateurs **Logo**.

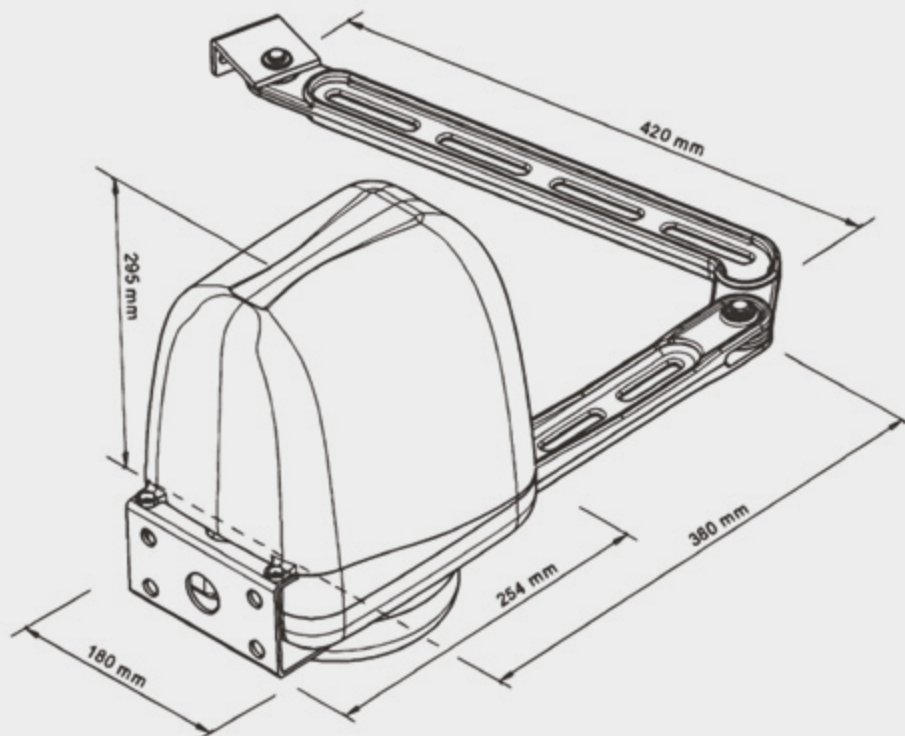

# Logo



## Logo / Max 250cm

**Cod. 2700000 / € 315,00**

Motoriduttore con braccio BDL incluso

Operator with arm BDL included

Motoreductor con brazo recto BDL incluido

Opérateur avec bras droit BDL inclus

## Logo+ / Max 250cm

**Cod. 2701000 / € 562,00**

Motoriduttore con centrale CLIMA24 e braccio BDL incluso

Operator with central unit CLIMA24 and arm BDL included

Motoreductor con controladora CLIMA24 y brazo recto BDL incluido

Opérateur avec centrale de commande CLIMA24 et bras droit BDL inclus

## Kit small

### Logo / Max 250cm

**Cod. 2701200 / € 804,00**

- 2 attuatori 24Vdc
- 1 centrale CLIMA24
- 2 telecomandi STAR2
- Kit ancoraggio
- BDL

- 2 operators 24Vdc
- 1 central unit CLIMA24
- 2 remote controls STAR2
- Mounting kit
- BDL

- 2 operadores 24Vdc
- 1 controladora CLIMA24
- 2 mandos STAR2
- kit de anclajes
- BDL

- 2 opérateurs 24Vdc
- 1 centrale de commande CLIMA24
- 2 télécommandes STAR2
- kit de montage
- BDL

## Kit top

### Logo / Max 250cm

**Cod. 2701211 / € 856,00**

- 2 attuatori 24Vdc
- 1 centrale CLIMA24
- 2 telecomandi STAR2
- 1 REX20 fotocellule
- 1 LUX lampeggiante
- kit ancoraggio
- BDL

- 2 operators 24Vdc
- 1 central unit CLIMA24
- 2 remote controls STAR2
- 1 REX20 photocells
- 1 LUX flashing light
- Mounting kit
- BDL

- 2 operadores 24Vdc
- 1 controladora CLIMA24
- 2 mandos STAR2
- 1 REX20 fotocélulas
- 1 LUX lámpara
- Kit de anclajes
- BDL

- 2 opérateurs 24Vdc
- 1 centrale de commande CLIMA24
- 2 télécommandes STAR2
- 1 REX20 photocellules
- 1 LUX lampe clignotante
- Kit de montage
- BDL

## Parts

### BDL / 420mm

**Cod. 9058100 / € 75,00**

Braccio dritto completo, anticesoimento, lungo 420mm

Anti-shearing arm, 420mm long

Brazo recto completo, antiplastiamento, lungo 420mm

Bras droit complet, anticisaillement, longueur 420mm

# Accessories



## **Clima 230 / 230Vac**

**Cod. 9210000 / € 222,00**

Centrale elettronica 230Vac a microprocessore per il controllo di cancelli a 2 ante con ricevitore incorporato a 433,92MHz adatta per motori con o senza frizione. Rallentamenti apertura/chiusura regolabili

Control unit 230Vac with microprocessor for swing gates, suitable for operators with or without clutch with box. Receiver 433,92MHz built-in. Adjustable slowing down feature on opening/closing

Cuadro de maniobra 230Vac con microprocessor para automatismos a puertas de 2 hojas con receptor incorporado de 433,92MHz. Ralentizaciones ajustablea en apertura/cierre

Centrale de commande 230Vac à microprocesseur pour portails à battants avec récepteur incorporé à 433,92MHz pour des moteurs avec ou sans embrayage. Ralentissements réglables en ouverture/fermeture

## **Clima 24 / 24Vdc**

**Cod. 9320000 / € 360,00**

Centrale elettronica 24Vdc a microprocessore per il controllo di cancelli a 2 ante con ricevitore incorporato a 433,92MHz e trasformatore. Rallentamenti apertura/chiusura regolabili

Control unit 24Vdc with microprocessor for swing gates, suitable for operators. Receiver 433,92MHz built-in and transformer. Adjustable slowing down feature on opening/closing

Cuadro de maniobra 24Vdc con microprocessor para automatismos a puertas de 2 hojas con receptor incorporado de 433,92MHz y transformador. Ralentizaciones ajustablea en apertura/cierre

Centrale de commande 24Vdc à microprocesseur pour portails à battants avec récepteur incorporé à 433,92MHz avec transformateur. Ralentissements réglables en ouverture/fermeture

## **Elettro / 12Vdc**

**Cod. 9400000 / € 100,00**

Elettroserratura orizzontale 12Vdc 1 anta

Horizontal electro-lock 12Vdc 1 leaf

Electrocerradura horizontal 12Vdc para una hoja

Electroserrure horizontale 12Vdc pour 1 vantail



# ***Porte basculanti***

***Garage doors / Puertas de garaje / Portes de garage***



***Thorx***

***Railx***

***Randy***

# Thorx

230 Vac

100% Produced in Italy

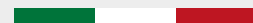

 **Thorx** è un motoriduttore elettromeccanico per porte basculanti contrappesate potente e silenzioso. Dimensione massima porta: 10mq

 **Thorx** is a powerful running electromechanical operator for residential projecting and non-projecting up-and-over garage doors. Maximum door's dimensions: 10mq

 **Thorx** es un motoreductor electromecánico para puertas basculantes contrapesadas fuerte y silencioso. Máximo tamaño de la puerta: 10mq

 **Thorx** est un opérateur électromécanique puissant et silencieux pour portes résidentielles basculantes à contrepoids. Dimensions maximum de la porte: 10mq

**Thorx**

**Thorx**

## DATI TECNICI / TECHNICAL DATA

**Thorx**

ALIMENTAZIONE GENERALE / MAIN POWER SUPPLY	230 Vac 50/60 Hz
ALIMENTAZIONE / MOTOR POWER SUPPLY	230 Vac 50/60 Hz
TEMPERATURA DI ESERCIZIO / OPERATING TEMPERATURE	-20° +55°
DIMENSIONI MAX PORTA / MAX DOOR SIZE	VEDERE GRAFICO / SEE GRAPH
POTENZA MOTORE / MOTOR POWER	250 w
ASSORBIMENTO / ABSORBED POWER	1,3 A
CONDENSATORE / CAPACITOR	12,5 µF
GIRI MOTORE / ENGINE REVOLUTIONS	1400 RPM
PESO MOTORE / WEIGHT	8 KG
GRADO IP / IP	30
LUBRIFICAZIONE / LUBRIFICATION	Grasso Permanente / Permanent Grease

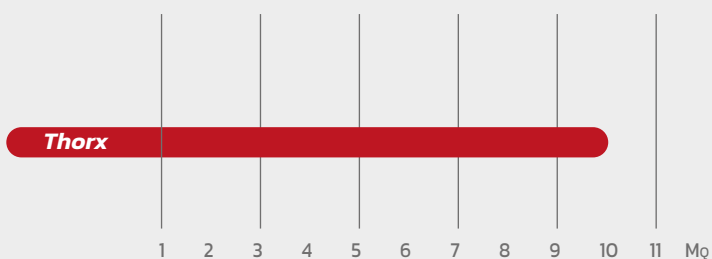

- Dimensioni massime azionabili dai motori **Thorx**.
- Maximum doors dimensions for **Thorx** operators.
- Tamaño máximo accionable por los motores **Thorx**.
- Dimensions maximum de la porte pour les opérateurs **Thorx**.

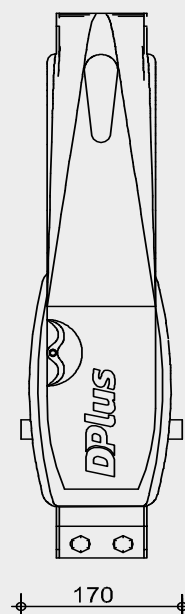
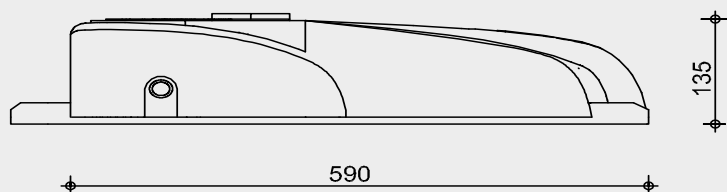



## Thorx - MOTOR

**Cod. 3000003 / € 336,00**

Motoriduttore 230Vac  
IRREVERSIBILE

Gear motor 230Vac  
IRREVERSIBLE

Motoreductor 230Vac  
IRREVERSIBLE

Opérateur 230Vac  
IRREVERSIBLE

## Kit

### Thorx - PLUS

**Cod. 3000002 / € 524,00**

- Motoriduttore
- centrale di comando METRA230
- fine corsa
- encoder

- Gear motor
- control unit METRA230
- limit switch
- encoder

- Motoreductor
- controladora METRA230
- finales de carrera
- encoder

- Opérateur
- Platine METRA230
- fins de course
- encoder

## Parts

### BD

**Cod. 9306000 / € 89,00**

Coppia di bracci dritti zincati  
completi di staffe di supporto

Pair of galvanized straight arms  
with supports

Par de brazos rectos  
galvanizados con soportes

Paire de bras droits zingués  
avec pattes de support

### BDB

**Cod. 9308000 / € 99,00**

Coppia di bracci dritti zincati  
con boccola completi di staffe di  
supporto

Pair of galvanized straight  
arms with welding bushes and  
supports

Par de brazos rectos  
galvanizados con casquillos y  
soportes

Paire de bras droits zingués  
avec bagues et pattes de  
support

### BC

**Cod. 9307000 / € 170,00**

Coppia di bracci curvi zincati  
completi di staffe di supporto

Pair of galvanized bowed arms  
with supports

Par de brazos curvos  
galvanizados con soportes

Paire de bras courbés zingués  
avec pattes de support

### BCB

**Cod. 9309000 / € 218,00**

Coppia di bracci curvi zincati  
con boccola completi di staffe  
di supporto

Pair of galvanized bowed  
arms with welding bushes  
and supports

Par de brazos curvos  
galvanizados con casquillos  
y soportes

Paire de bras courbés  
zingués avec bagues et  
pattes de support

### TB2M

**Cod. 9304000 / € 101,00**

Coppia di tubi zincati con  
boccola, completi di staffe di  
supporto, 2 metri

Pair of pipes with welding  
bushes and supports,  
2 meters-long

Par de tubos galvanizados  
con casquillos y soportes,  
2 metros

Paire de tubes zingués avec  
bagues et pattes de support,  
2 mètres

### KITTB2

**Cod. 9304001 / € 190,00**

- 2 tubi con boccola
- Coppia di bracci dritti zincati  
con staffe di supporto

- Pair of pipes with welding  
bushes
- Pair of galvanized straight  
arms with supports

- 2 tubos con casquillo
- Par de brazos rectos  
galvanizados con soportes

- 2 tubes avec bagues
- Paire de bras droits zingués  
avec pattes de support

### L65 - 650MM

**Cod. 9300650 / € 22,00**

### L190 - 1900MM

**Cod. 9301900 / € 67,00**

Lamierone

Motor sheet support

Soporte del motor

Longeron tôle

### FC

**Cod. 9303000 / € 22,00**

Kit 2 fincorsa da montare

Kit 2 electro-mechanical limit  
switches to install

Kit 2 finales de carrera para  
instalar

Kit 2 fins de course à  
assembler

### Metra230 / 230 Vac

**Cod. 8010000 / € 190,00**

Centrale con rallentamenti  
apertura/chiusura regolabili.  
Ricevente integrata

Control unit with adjustable  
slowing down feature on  
opening/closing. Built-in  
receiver

Cuadro de maniobra con  
disminucion de velocidad  
apertura/cierre ajustable  
y receptor incorporado

Centrale de commande avec  
ralentissements ouverture/  
fermeture réglables avec  
récepteur incorporé

# Railx

24 Vdc

100% Produced in Italy

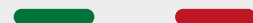

 **Railx** è un motoriduttore per porte sezionali ad uso residenziale, con luce di cortesia interna a led

 **Railx** is an operator to open residential sectional door, with led internal service light

 **Railx** es un motoreductor para puertas seccionales de uso residencial con luz de servicio a led integrada

 **Railx** est un opérateur sectionnelle pour un usage résidentiel, avec lumière de courtoisie interne à led

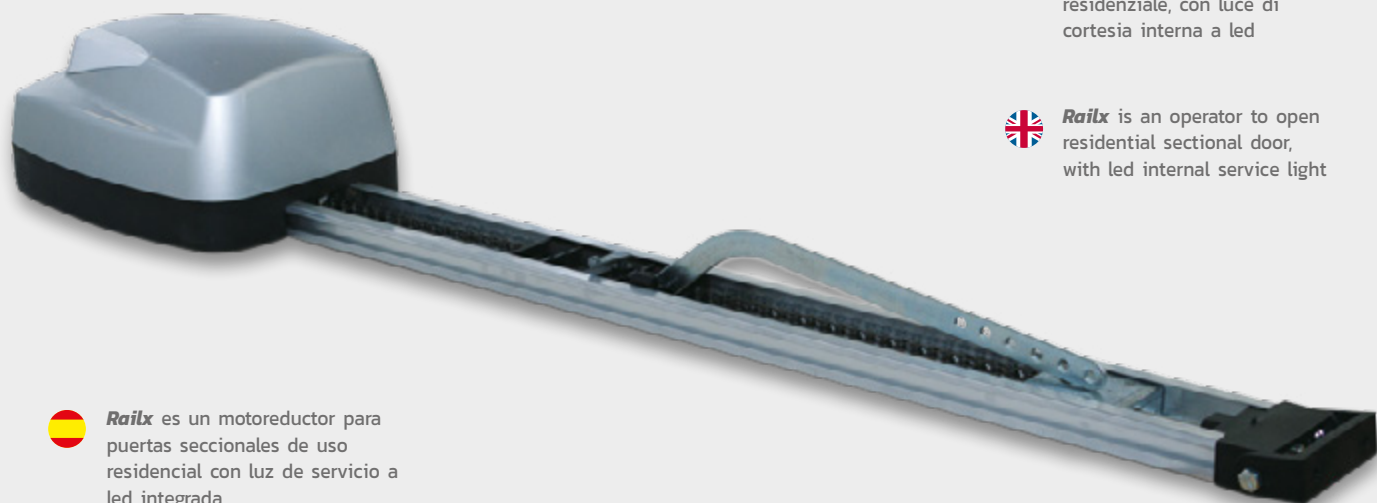



**DATI TECNICI / TECHNICAL DATA** **Railx 800** **Railx 1200**

ALIMENTAZIONE GENERALE / MAIN POWER SUPPLY	110/230 Vac	110/230 Vac
ALIMENTAZIONE MOTORE / POWER SUPPLY	24 Vdc	24 Vdc
TEMPERATURA DI ESERCIZIO / OPERATING TEMPERATURE	-20° +55°	-20° +55°
LARGHEZZA MAX PORTA / MAXIMUM WIDTH DOOR	3 M	4,5 M
SPINTA / TORQUE FORCE	700 N	1000 N
ASSORBIMENTO / ABSORBED POWER	0,7 A	1,2 A
PESO MOTORE / WEIGHT	4 KG	5 KG
GRADO IP / IP	30	30
TEMPO DI APERTURA / OPENING TIME	22 SEC	22 SEC

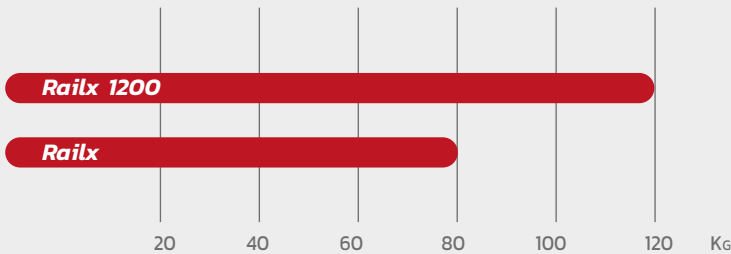

- Forza di sollevamento dei motori **Railx**.
- Maximum lifting power for **Railx** operators.
- Fuerza de elevación de los motores **Railx**.
- Force de levage des moteurs **Railx**.

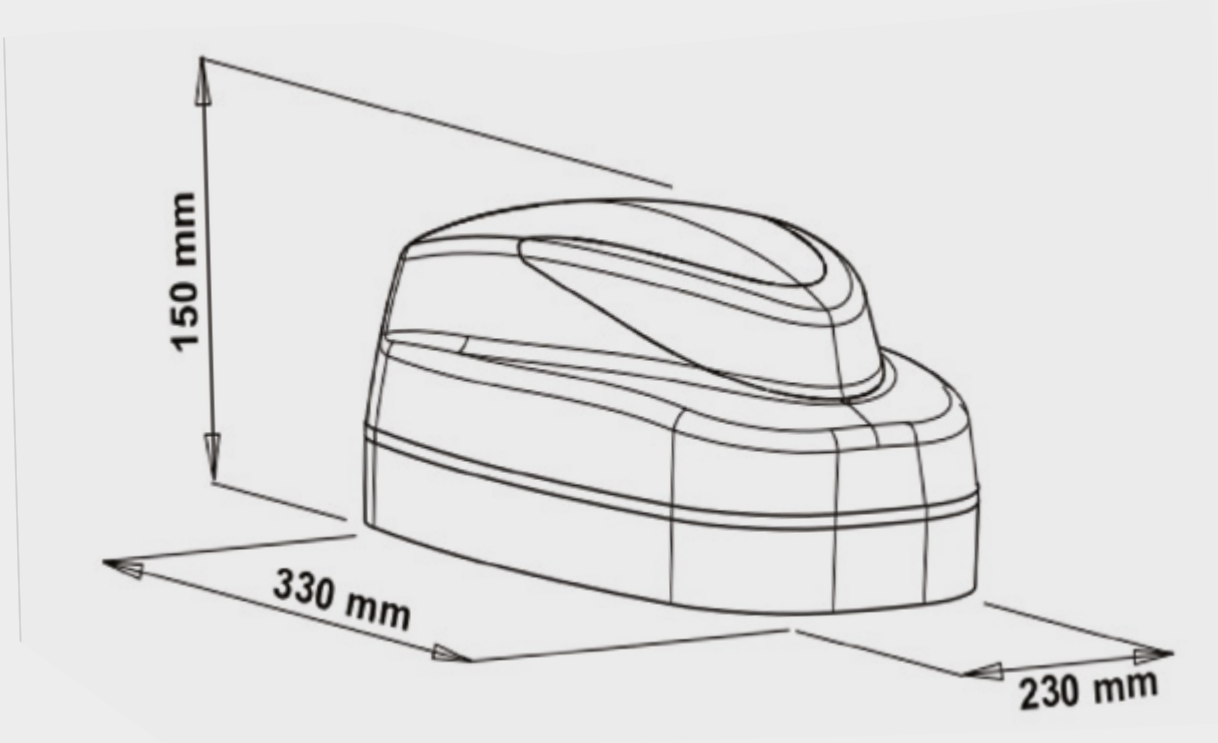



## Railx 800 / 24V – 800Newton

**Cod. 3101000 / € 250,00**

- Motoriduttore
- centrale di comando
- ENCODER

- Gear motor
- control unit
- ENCODER

- Motoreductor
- controladora
- ENCODER

- Opérateur
- centrale de commande
- ENCODER

## Railx 1200 / 24V – 1200Newton

**Cod. 3121000 / € 288,00**

- Motoriduttore
- centrale di comando
- ENCODER

- Gear motor
- control unit
- ENCODER

- Motoreductor
- controladora
- ENCODER

- Opérateur
- centrale de commande
- ENCODER

## Parts

### GR3 – 3M

**Cod. 9310000 / € 100,00**

Guida di 3m assemblata in ferro con accessori

3m assembled iron made rail with accessories

Guía 3mts assemblada de hierro con accesorios

Rail 3m en iron assemblé avec accessoires

### GR4 – 4M

**Cod. 9311000 / € 120,00**

Guida di 4m assemblata in ferro con accessori

4m assembled iron rail with accessories

Guía 4mts assemblada de hierro con accesorios

Rail 4m en iron assemblé avec accessoires

### Charge / 24V

**Cod. 9312000 / € 40,00**

Carica batterie 24Vdc per Railx

Charger for Railx 24Vdc

Cargador de baterias para Railx 24Vdc

Chargeurs pour Railx 24Vdc

### Ark

**Cod. 9315000 / € 125,00**

Archetto per porte basculanti a contrappeso

Curved arm for counterweight doors

Soporte para puertas basculantes contrapesada

Arc pour portes basculantes à contrepoids

### Blok

**Cod. 9316000 / € 50,00**

Sblocco con serratura

Release device with lock

Desbloqueo con cerraje

Déverouillage avec serrure







# Randy

**110-230 Vac**

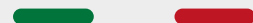
100% Produced in Italy



 **Randy** è un motoriduttore elettromeccanico per serrande bilanciate fino a 350kg di sollevamento

 **Randy** is an electromechanical gear motor for lifting balanced rolling shutters up to 350kg

 **Randy** es un motoreductor electromecánico para compuertas equilibradas hasta 350 kg de levantamiento

 **Randy** est un opérateur électromécanique pour rideaux équilibrés jusqu'à 350 kg de soulèvement



DATI TECNICI / TECHNICAL DATA	<b>Randy 180</b>	<b>Randy 240</b>	<b>Randy 360</b>
ALIMENTAZIONE / POWER SUPPLY	220 Vac 50/60 Hz	220 Vac 50/60 Hz	220 Vac 50/60 Hz
TEMPERATURA DI ESERCIZIO / OPERATING TEMPERATURE	-20° +80°	-20° +80°	-20° +80°
ASSORBIMENTO / ABSORBED POWER	2 A	3 A	3,5 A
MOTORE ELETTRICO / ELETRIC MOTOR	Asincrono 4 poli 1400 RPM	Asincrono 4 poli 1400 RPM	Asincrono 4 poli 1400 RPM x 2
POTENZA / RATED POWER	400 w	600 W	800 W
CONDENSATORE / CAPACITOR	16 µF	20 µF	40 µF
FORZA DI SOLLEVAMENTO / LIFTING POWER	180 KG	250 KG	350 KG
VELOCITÀ CORONA MOTORE / CROWN SPEED	10 GIRI/MINUTO	10 GIRI/MINUTO	10 GIRI/MINUTO
DIAMETRO INTERNO / INTERNAL DIAMETER	60 MM	60 MM	76 MM
DIAMETRO ESTERNO / EXTERNAL DIAMETER	200 MM	200 MM	240 MM
PESO MOTORE / WEIGHT	7 KG	9 KG	13 KG
MAX ALTEZZA SERRANDA / SHUTTER MAX HEIGHT	8 M	8 M	8 M
TERMOPROTEZIONE / THERMAL PROTECTION	150°	150°	150°

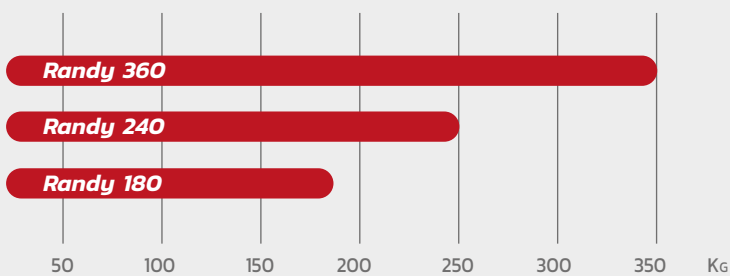

- Forza di sollevamento dei motori **Randy**.
- Maximum lifting power for **Randy** operators.
- Fuerza de elevación de los motores **Randy**.
- Force de levage des moteurs **Randy**.

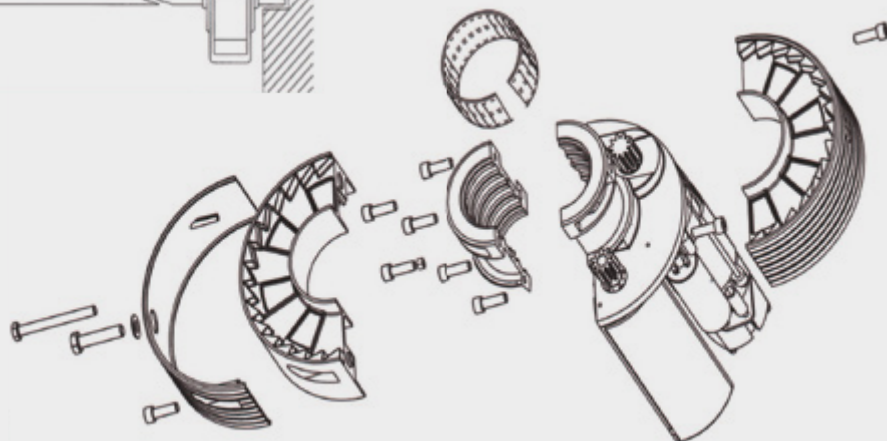
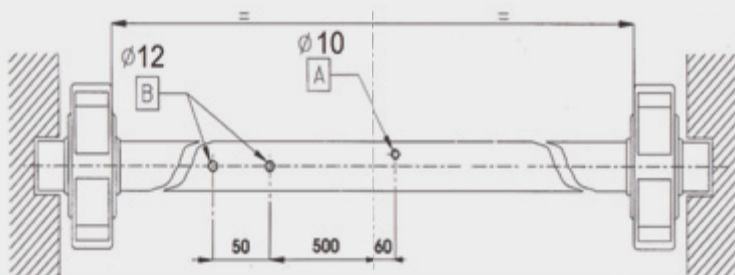



# Randy



## Randy 180

**Cod. 3200015 / € 215,00**

Motoriduttore 180kg, d. 60mm

Gear motor 180kg, d. 60mm

Motoreductor 180kg, d. 60mm

Opérateur 180kg, d. 60mm

## Randy 240

**Cod. 3200212 / € 460,00**

Motoriduttore doppio 250kg, d. 60mm con elettrofreno

Dual gear motor with electrobrake 250kg, d. 60mm

Motoreductor doble con electrofreno 250kg, d. 60mm

Opérateur double avec électrofrein 250kg, d. 60mm

## Randy 360

**Cod. 3200252 / € 600,00**

Motoriduttore doppio 350kg, d. 76mm con elettrofreno

Dual gear motor with electrobrake 350kg, d. 76mm

Motoreductor doble con electrofreno 350kg, d. 76mm

Opérateur double avec électrofrein 350kg, d. 76mm

## Parts

### Freno

**Cod. 3200001 / € 52,00**

Elettrofreno

Electrobrake

Electrofreno

Electrofrein

### Smart

**Cod. 3200000 / € 70,00**

Centrale 230Vac con ricevitore incorporato

Control board 230Vac with built-in receiver

Central electronica 230Vac con receptor incorporado

Centrale électronique 230Vac avec récepteur incorporé

### Sicur

**Cod. 3200002 / € 60,00**

Selettore di sicurezza per sblocco esterno con leva di sblocco

Security selector for outside release with release lever

Selector de seguridad para el desbloqueo desde el exterior con palanca de desbloqueo

Selecteur de sécurité pour déblocage de l'extérieur avec levier de deblocage

### Sicurplus

**Cod. 3200003 / € 65,00**

Selettore di sicurezza per sblocco esterno con pulsante e leva di sblocco

Security selector for outside release with button and release lever

Selector de seguridad para el desbloqueo desde el exterior con boton y palanca de desbloqueo

Selecteur de sécurité pour déblocage de l'extérieur avec bouton et levier de deblocage



# **Barriere**

**Barriers / Barreras vehiculares / Barrières**



**Pass**

**Pass speed**

**Zen**





# Pass & Pass Speed

100% Produced in Italy





## 24 Vdc

 **Pass** è una barriera elettromeccanica a 24 Vdc per uso semi-intensivo, max 6m

 **Pass** is an electromechanical barrier in 24 Vdc for semi-intensive use, max 6m

 **Pass** es una barrera electromecánica de 24 Vdc para uso semi-intensivo por max 6m

 **Pass** est une barrière électromécanique à 24 Vdc pour un usage semi-intensif, max 6m

 **Pass Speed** è una barriera elettromeccanica per uso intensivo con inverter, max 4m

 **Pass Speed** is an electromechanical barrier for intensive use with inverter, max 4m

 **Pass Speed** es una barrera electromecánica para uso intensivo con inverter, max. 4m

 **Pass Speed** est une barrière électromécanique pour un usage intensif avec inverter, max 4m



DATI TECNICI / TECHNICAL DATA	<i>Pass 4</i>	<i>Pass 6</i>	<i>Pass Speed</i>
ALIMENTAZIONE GENERALE / MAIN POWER SUPPLY	110/230 Vac	110/230 Vac	230 Vac
ALIMENTAZIONE MOTORE / POWER SUPPLY	24 Vdc	24 Vdc	400 Vac Three-phase
TEMPERATURA DI ESERCIZIO / OPERATING TEMPERATURE	-20° +55°	-20° +55°	-20° +55°
DIMENSIONI MAX ASTA / MAXIMUM BOOM LENGTH	4 M	6 M	4 M
POTENZA MOTORE / MOTOR POWER	60 W	60 W	750 W
SBLOCCO PER MANOVRA DI EMERGENZA / UNLOCK FOR EMERGENCY	MECHANICAL	MECHANICAL	MECHANICAL
PESO MOTORE / WEIGHT	45 KG	45 KG	50 KG
FINE CORSA / LIMIT SWITCH	ELECTROMECHANICAL	ELECTROMECHANICAL	ELECTROMECHANICAL
GRADO IP / IP	44	44	44
TEMPO DI APERTURA / OPENING TIME	6 SEC	9 SEC	3 SEC

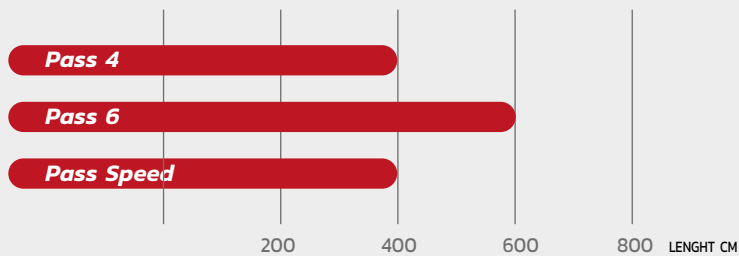

- Dimensioni massime azionabili della gamma **Pass**.
- Maximum dimensions for **Pass** operators.
- Tamaño máximo accionable por los motores de la gama **Pass**.
- Dimensions maximum pour barrières **Pass**.

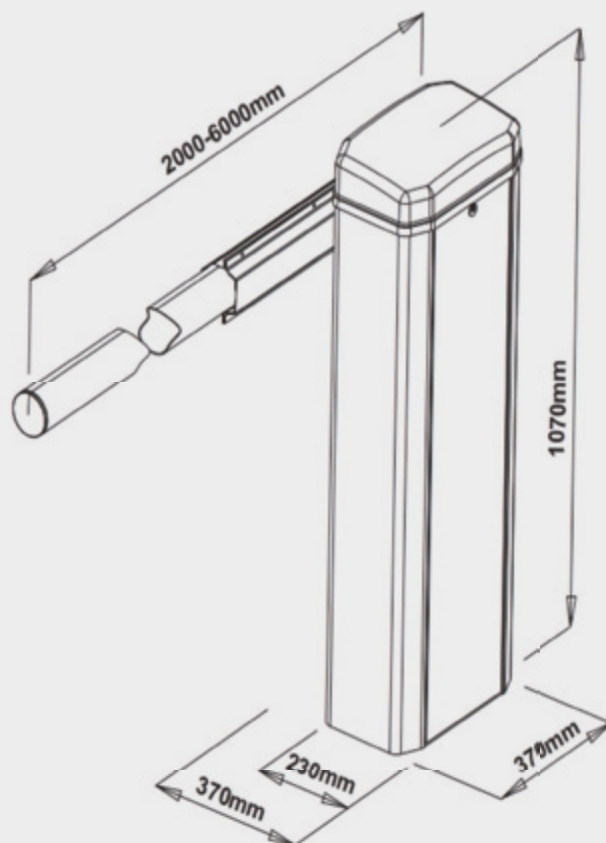



# Pass & Pass Speed



## Pass 4 / 24Vdc - 4m

Cod. 7204024 / € 1.248,00

- Barriera per braccio fino a 4m, 24Vdc
- Finecorsa
- Ricevente
- Centralina

- Barrier 24Vdc for 4m boom
- Control unit
- Limit switch
- Receiver

- Barrera 24Vdc para brazo 4m
- Controladora
- Finales de carrera
- Receptor

- Opérateur 24Vdc pour lisse 4m
- Centrale de commande
- Fin de course
- Recepteur

## Pass 6 / 24Vdc - 6m

Cod. 7206024 / € 1.694,00

- Barriera per braccio fino a 6m, 24Vdc
- Finecorsa
- Ricevente
- Centralina

- Barrier 24Vdc for 6m boom
- Control unit
- Limit switch
- Receiver

- Barrera 24Vdc para brazo 6m
- Controladora
- Finales de carrera
- Receptor

- Opérateur 24Vdc pour lisse 6m
- Centrale de commande
- Fin de course
- Recepteur

## Pass Speed / Inverter System

Cod. 7208024 / € 1.500,00

- Barriera per braccio fino a 4m
- Inverter
- Finecorsa
- Ricevente
- Centralina

- Barrier for 4m boom
- Inverter
- Control unit
- Limit switch
- Receiver

- Barrera para brazo 4m
- Inverter
- Controladora
- Finales de carrera
- Receptor

- Opérateur pour lisse 4m
- Inverter
- Centrale de commande
- Fin de course
- Recepteur

## Parts

### Asta 4M

Cod. 7200400 / € 200,00

Asta alluminio 4m, d. 80mm

Aluminium-made boom for barriers 4m, d. 80mm

Barrazo de aluminio para barrera 4m, d. 80mm

Lisse pour barrière en aluminium 4m, d. 80mm

### Asta 6M

Cod. 7200600 / € 300,00

Asta alluminio 6m, d. 80mm

Aluminium-made boom for barriers 6m, d. 80mm

Barrazo de aluminio para barrera 6m, d. 80mm

Lisse pour barrière en aluminium 6m, d. 80mm

### Controbasse

Cod. 7201000 / € 46,00

Piastra di ancoraggio

Foundation plate

Placa de anclaje

Plaque de fondation

### METRA 24 / 24Vdc

Cod. 8015000 / € 198,00

Centrale con rallentamenti apertura/chiusura, ricevente e carica batterie integrate con memoria per 254 telecomandi

Control unit with adjustable slowing down feature for opening/closing, built-in receiver and battery charger with memory for up to 254 remotes

Cuadro de maniobra con ralentizaciones en apertura/cierre, receptora y cargabaterias integrados con memoria de 254 mandos

Centrale de commande avec ralentissements en ouverture/fermeture, récepteur et chargeur de batterie incorporés avec mémoire jusqu' à 254 émetteurs

### ELEKTRA / 400 Vac Inverter

Cod. 8019000 / € 495,00

Centrale elettronica 400Vac per barriera con tecnologia inverter

Control unit 400Vac for barrier with inverter technology

Cuadro de maniobra 400 Vac para barreras con tecnologia inverter

Centrale électronique 400Vac pour barrières avec technologie inverter

# Zen

## 230 Vac

100% Produced in Italy

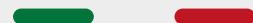

 **Zen** è una barriera automatica a catena per varchi da 2 a 16 mt

 **Zen** is an automatic chain barrier for openings from 2 to 16 mt

 **Zen** es una barrera de cadena automática para aperturas de 2 a 16 mt

 **Zen** est une barrière automatique à chaîne pour les ouvertures de 2 à 16 mt



**DATI TECNICI / TECHNICAL DATA**
**Zen**

ALIMENTAZIONE GENERALE / MAIN POWER SUPPLY	230 Vac 50 Hz
POTENZA MOTORE / MOTOR POWER	60 W
TEMPERATURA DI ESERCIZIO / OPERATING TEMPERATURE	-20° +50°
COPPIA / MOTOR TORQUE	645 Ncm
USO / USE	Intensivo / Intensive
ASSORBIMENTO / ABSORBED POWER	1,0 A
CICLO (lavoro/pausa) / DUTY	50%
TEMPO DI APERTURA / OPENING TIME	10-11 SEC
PESO MOTORE / WEIGHT	25 KG
GRADO IP / IP	IP55
LUBRIFICAZIONE / LUBRIFICATION	Permanente / Permanent

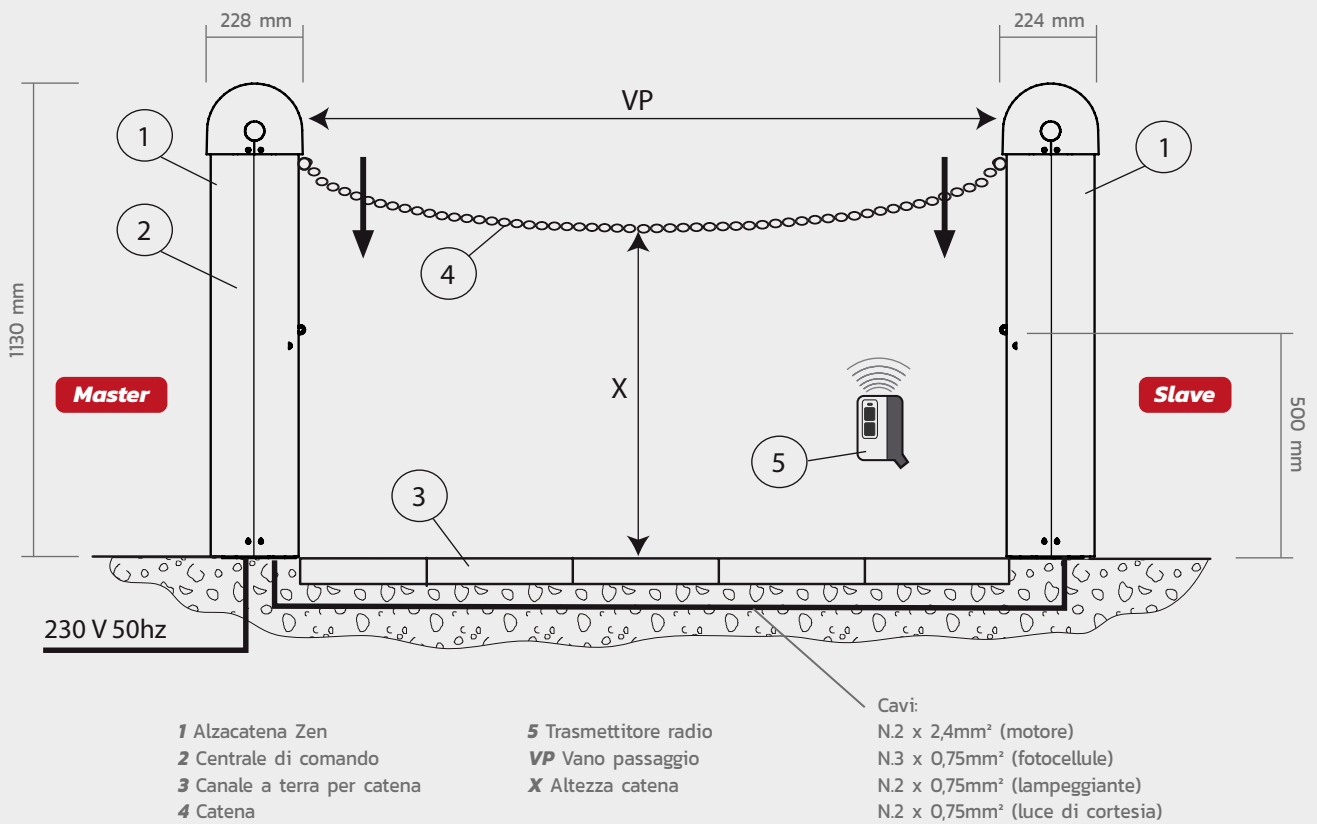
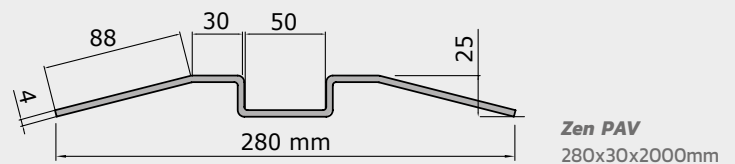
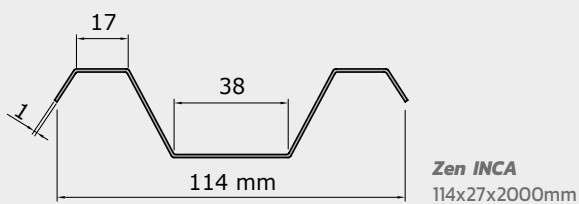
**Guide di protezione / Chain protection / Guías de proteccion / Rail de protection**



## Zen Master

**Cod. 7300000 / € 1.990,00**

- Barriera automatica a catena 24Vdc (colonna singola destra o sinistra)
- Centralina
- Radioricevitore 868 Mhz incorporato
- 2 schede lampeggiatore
- 1 spot luce led bianca fissa ad alta luminosità 1W, IP66 (per l'accensione dello spot, l'interruttore crepuscolare non è fornito)

- 24vdc automatic chain barrier (single right or left column)
- Control unit
- Built-in 868 Mhz radio receiver
- 2 flasher boards
- 1 high-brightness fixed white LED spot light 1W, IP66 (no twilight switch is provided for switching on the spot)

- Barrera de cadena automática 24Vdc (columna única derecha o izquierda)
- Cuadro de maniobra
- Receptor de radio de 868 Mhz integrado
- 2 tarjetas intermitentes
- 1 foco de luz LED blanca fija de alto brillo de 1 W, IP66 (para encender el foco, no se suministra el interruptor crepuscular)

- Barrière automatique à chaîne 24Vdc (colonne unique droite ou gauche)
- Centrale de control
- Récepteur radio 868 Mhz intégré
- 2 cartes clignotantes
- 1 spot lumineux à LEDs blanches fixes haute luminosité 1W, IP66 (pour allumer le spot, l'interrupteur crépusculaire n'est pas fourni)

## Zen Slave

**Cod. 7300001 / € 1.350,00**

- Barriera automatica a catena (colonna singola destra o sinistra) senza centrale
- 1 spot luce led bianca fissa ad alta luminosità 1W, IP66

- Automatic chain barrier (single right or left column) without control unit
- 1 high-brightness fixed white LED spot light 1W, IP66

- Barrera de cadena automática (columna única derecha o izquierda) sin cuadro
- 1 foco de luz LED blanco fijo de alta luminosidad 1W, IP66

- Barrière automatique à chaîne (colonne simple droite ou gauche) sans centrale
- 1 spot lumière LED blanche fixe haute luminosité 1W, IP66

## Zen PF

**Cod. 7300002 / € 40,00**

- Piastra di fondazione zincata a murare completa di tirafondi. Confezione singola

- Galvanized foundation plate complete with anchors. Single pack

- Placa de cimentación galvanizada para fijar al suelo completa con pernos de anclaje. Envasado individualmente

- Plaque de fondation galvanisée à fixer au sol complète avec boulons d'ancrage. Emballage individuel

## Zen CAT

**Cod. 7300003 / € 108,00**

- Confezione 8mt. Catena zincata ø5 mm

- 8m package. ø5 mm galvanized chain

- Embalaje 8mt. Cadena galvanizada ø5 mm

- Paquet 8mt. Chaîne galvanisée par ø5 mm

## Zen CAT 2

**Cod. 7300004 / € 141,00**

- Confezione 8mt. Catena verniciata di colore rosso ø5mm

- 8mt package. Red painted chain ø5 mm

- Embalaje 8mt. Cadena pintada de color rojo ø5 mm

- Paquet 8mt. Chaîne peinte rouge ø5 mm

## Zen CAT 3

**Cod. 7300005 / € 286,00**

- Confezione 16mt. Catena verniciata di colore rosso ø5 mm

- 16mt package. Red painted chain ø5 mm

- Embalaje 16mt. Cadena pintada de color rojo ø5 mm

- Paquet 16mt. Chaîne peinte rouge ø5 mm

## Zen CAT 4

**Cod. 7300006 / € 219,40**

- Confezione 16mt. Catena zincata ø5 mm

- 16mt package. ø5 mm galvanized chain

- Embalaje 16mt. Cadena galvanizada ø5 mm

- Paquet 16mt. Chaîne galvanisée par ø5 mm

**Zen INCA****Cod. 7300007 / € 94,00**

- Guide di protezione catena ad incasso 2mt
- Recessed chain protection guides 2mt
- Guías de protección de cadena empotradas 2mt
- Rail extérieur de protection de chaîne à encastrer 2mt

**Zen PAV****Cod. 7300008 / € 310,00**

- Guide di protezione catena a pavimento 2mt
- Floor chain protection guides 2mt
- Guías de protección de la cadena de piso 2mt
- Guides de protection de la chaîne au sol 2mt

**Zen RING****Cod. 7300009 / € 30,00**

- Anello di sicurezza per catena metallica
- Safety ring for metal chain
- Anilla de seguridad para cadena metálica
- Anneau de sécurité pour chaîne métallique

**Zen BAT****Cod. 7300010 / € 89,00**

- Batteria 12 volt con staffa di supporto per funzionamento in caso di mancanza della tensione di rete. Gestione batteria prevista nella centralina di comando
- 12 volt battery with support bracket for operation in case of lack of mains voltage. Battery management provided in the control unit
- Batería de 12 voltios con soporte de apoyo para el funcionamiento en caso de fallo de la red eléctrica. Gestión de la batería en el cuadro de maniobra
- Batterie de 12 volts avec support pour le fonctionnement en cas de panne de courant. Gestion de la batterie assurée par la centrale de commande



# **Porte automatique**

**Automatic sliding doors / Puertas automaticas / Portes automatiques**



**Velaks**

**Horus**

# Velaks 24 Vdc

100% Produced in Italy

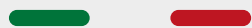

**Velaks** è un operatore per porte automatiche scorrevoli  
max 150Kg / 1 anta  
max 100 + 100Kg / 2 ante



**Velaks** es un operador para puertas automaticas corredizas  
max 150Kg / 1 hoja  
max 100 + 100Kg / 2 hojas



**Velaks** is a an operator to open automatic sliding doors  
max 150Kg / 1 leaf  
max 100 + 100Kg / 2 leaves



**Velaks** est un opérateur pour portes automatiques coulissantes  
max 150Kg / 1 vantail  
max 100 + 100Kg / 2 vantaux



**DATI TECNICI / TECHNICAL DATA****Velaks**

ALIMENTAZIONE GENERALE / MAIN POWER SUPPLY	110/230 Vac
ALIMENTAZIONE MOTORE / POWER SUPPLY	24 Vdc
POTENZA / POWER	50 W
PORTATA MASSIMA PER 1 ANTA / MAX LOAD CAPACITY FOR 1 LEAF	150 KG
PORTATA MASSIMA PER 2 ANTE / MAX LOAD CAPACITY FOR 2 LEAVES	100 + 100 KG
BATTERIE / BACK UP BATTERIES	OPTIONAL
APERTURA MASSIMA / MAXIMUM OPENING	2900 MM
ENCODER / ENCODER	OTTICO 100 IMPULSI / OPTICAL 100 PULSES

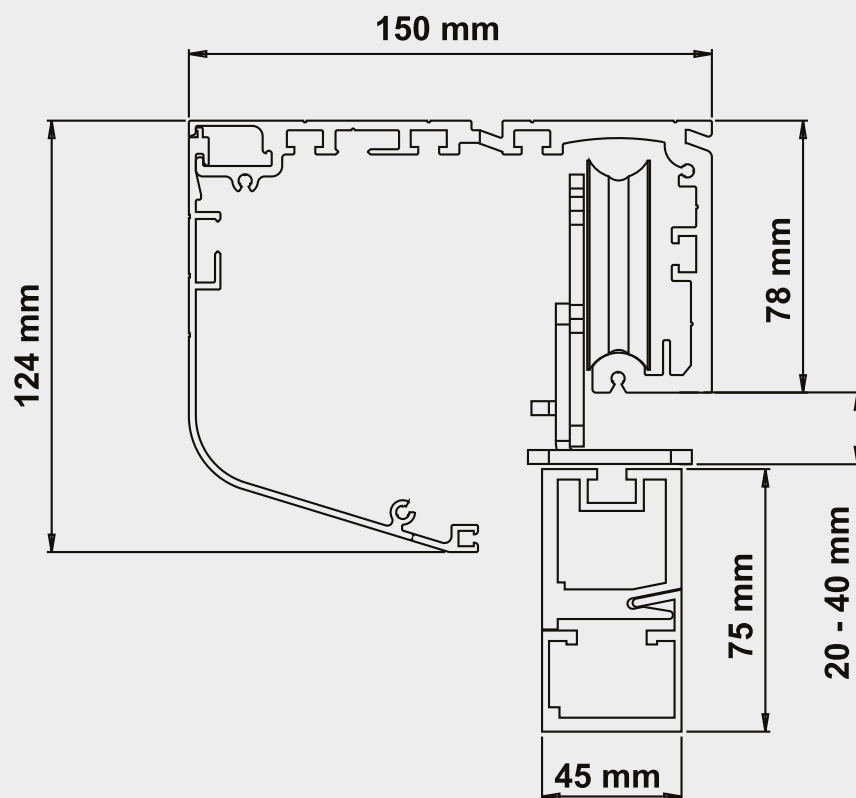
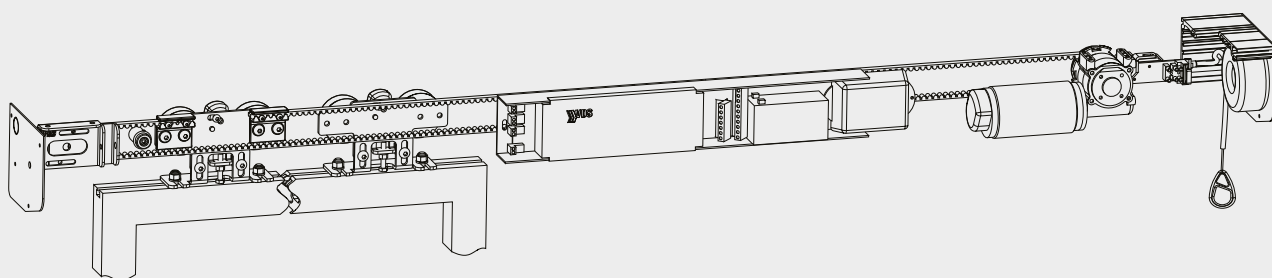

# Velaks



## Velaks 1A4M

**Cod. 3300104 / € 1.950,00**

- Modulo motoriduttore
- Traversa 1 anta 4.370mm, peso max. 150kg, larghezza passaggio 2.100mm

- Gearbox module
- Crossbeam 1 door 4.370mm, max. weight 150kg, max. opening 2.100mm

- Modulo motoreductor
- Travesano 1 puerta 4.370mm, max 150kg, apertura max. 2.100mm

- Module motoréducteur
- Traverse 1 vantail 4.370mm, max 150kg, ouverture max 2.100mm

## Velaks 1A6M

**Cod. 3300106 / € 2.050,00**

- Modulo motoriduttore
- Traversa 1 anta 5.970mm, peso max. 150kg, larghezza passaggio 2.900mm

- Gearbox module
- Crossbeam 1 door 5.970mm, max. weight 150kg, max. opening 2.900mm

- Modulo motoreductor
- Travesano 1 puerta 5.970mm, max 150kg, apertura max. 2.900mm

- Module motoréducteur
- Traverse 1 vantail 5.970mm, max 150kg, ouverture max 2.900mm

## Velaks 2A4M

**Cod. 3300204 / € 2.000,00**

- Modulo motoriduttore
- Traversa 2 ante 4.320mm, peso max. 100 + 100kg, larghezza passaggio 2.100mm

- Gearbox module
- Crossbeam 2 doors 4.320mm, max. weight 100 + 100kg, max. opening 2.100mm

- Modulo motoreductor
- Travesano 2 puertas 4.320mm, max 100 + 100kg, apertura max. 2.100mm

- Module motoréducteur
- Traverse 2 vantaux 4.320mm, max 100 + 100kg, ouverture max 2.100mm

## Velaks 2A6M

**Cod. 3300206 / € 2.100,00**

- Modulo motoriduttore
- Traversa 2 ante 5.920mm, peso max. 100 + 100kg, larghezza passaggio 2.900mm

- Gearbox module
- Crossbeam 2 doors 5.920mm, max. weight 100 + 100kg, max. opening 2.900mm

- Modulo motoreductor
- Travesano 2 puertas 5.920mm, max 100 + 100kg, apertura max. 2.900mm

- Module motoréducteur
- Traverse 2 vantaux 5.920mm, max 100 + 100kg, ouverture max 2.900mm

## Parts

### Rexmini

**Cod. 9040001 / € 95,00**

Fotocellula miniaturizzata singolo raggio

Single sweep miniaturised photocell

Fotocélula miniaturizada de rayo simple

Photocellule miniaturisée rayon simple

### Radar

**Cod. 9050000 / € 150,00**

Sensore a microonde 5m

Microwaves sensor 5m range

Radar por microondas hasta 5m

Sensor à microwaves jusqu' à 5m

### Keydoor

**Cod. 9022100 / € 70,00**

Selettore per porte automatiche

Automatic doors key switch

Selector para puertas automaticas

Sélecteur à clé pour portes automatiques

### Floor-glass

**Cod. 9070010 / € 20,00**

Guida a pavimento per anta cristallo

Floor guide for glass leaf

Guia de piso para hoja de cristal

Profilé de plancher pour vanatil en verre

### Velablok

**Cod. 9070020 / € 200,00**

Elettroblocco completo

Complete electrolock

Bloqueo electromecanico

Electro-blocage complet

# Velaks

Parts 



## Agg

Cod. 9070000 / € 146,00

Sistema aggancio cristallo  
(prezzo al metro)

Support profile for glass leaves  
(price per m)

Soporte para hojas de cristal  
(precio por m)

Système vantail en verre  
(prix pour m)

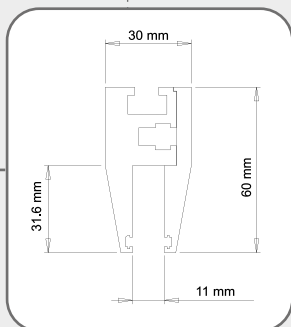

## Prof-O

Cod. 9070030 / € 43,00

Profilo anta orizzontale in  
alluminio, 1m

Horizontal door frame  
aluminium profile, 1m

Perfil de la hoja de aluminio  
horizontal, 1m

Profil horizontal pour vantail  
aluminium, 1m

## Prof-V

Cod. 9070040 / € 43,00

Profilo anta verticale in  
alluminio, 1m

Vertical door frame  
aluminium profile, 1m

Perfil de la hoja de aluminio  
vertical, 1m

Profil vertical pour vantail  
aluminium, 1m.

## Floor

Cod. 9070050 / € 22,00

Guida a pavimento

Floor guide

Guía de piso

Profile de plancher

## Spazz

Cod. 9070060 / € 36,00

Spazzolino, 1m

Brush, 1m

Cepillo, 1m

Brosse, 1m

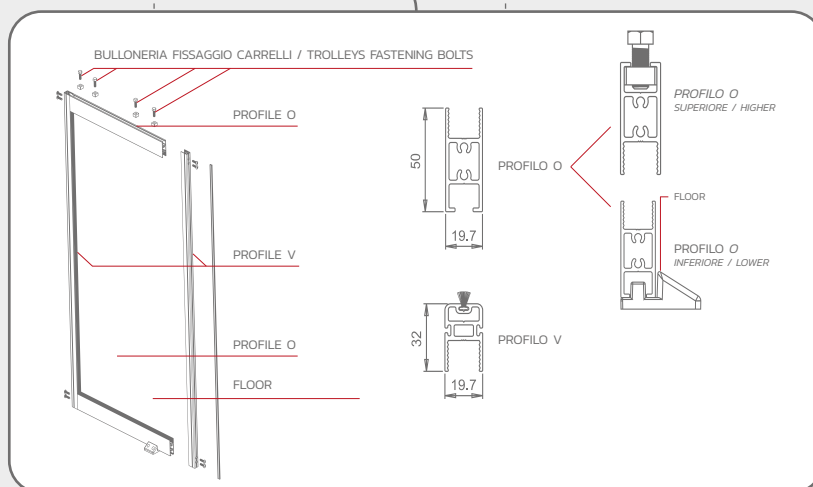





# Horus

100% Produced in Italy

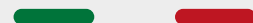

**24 Vdc**

-  Tornello automatico potenziabile con dispositivo conta-persone e con rilevatore di temperatura corporea e utilizzo mascherina
-  Automatic turnstile available with people-counter system and body temperature and face mask detector
-  Torniquete automático disponible con dispositivo de conteo de personas y con detector de temperatura corporal y uso de máscara
-  Tourniquet automatique disponible avec dispositif de comptage de personnes et avec détecteur de température corporelle et utilisation du masque



## DATI TECNICI / TECHNICAL DATA

**Horus**

GRADO IP / IP	44
ALIMENTAZIONE / POWER SUPPLY	120/230 Vac
ALIMENTAZIONE MOTORE / POWER SUPPLY	24 Vdc
ASSORBIMENTO / ABSORBED POWER	3,5 A
POTENZA / RATED POWER	120 W
TEMPERATURA DI ESERCIZIO / OPERATING TEMPERATURE	-20° +55°
CLASSE DI ISOLAMENTO / INSULATION SYSTEM	350 KG
PESO / WEIGHT	25 KG
TEMPO DI APERTURA / OPENING TIME	2-3 SEC

# Installation examples

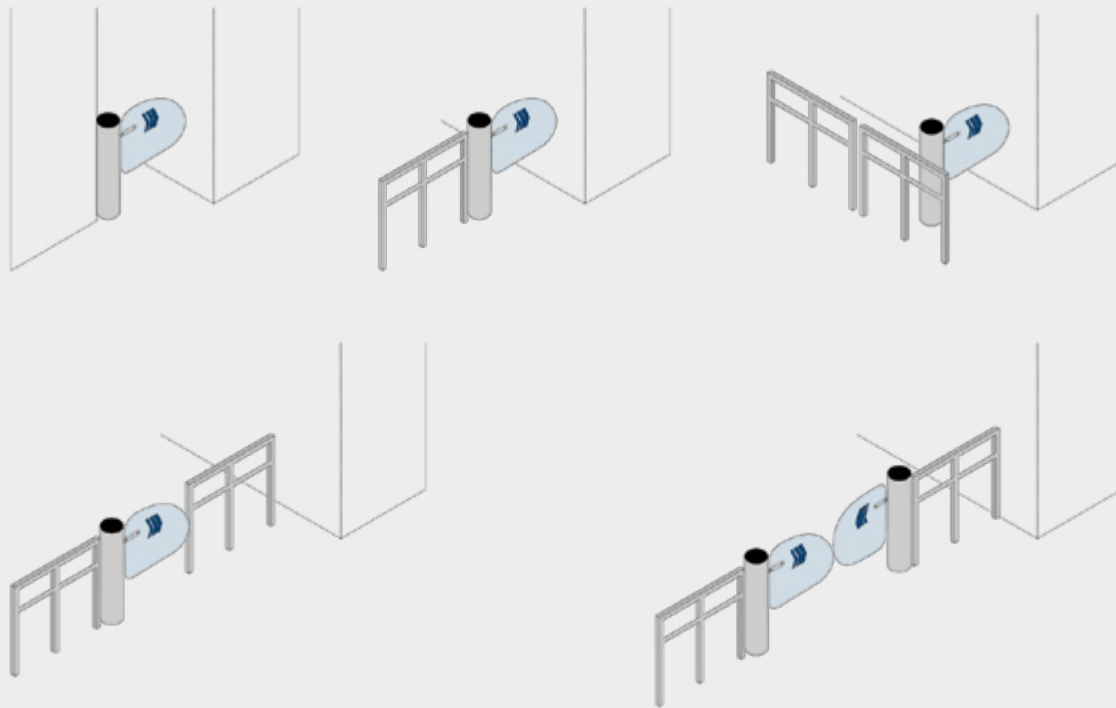

## Dimensions

**Horus 600**

**Horus 900**

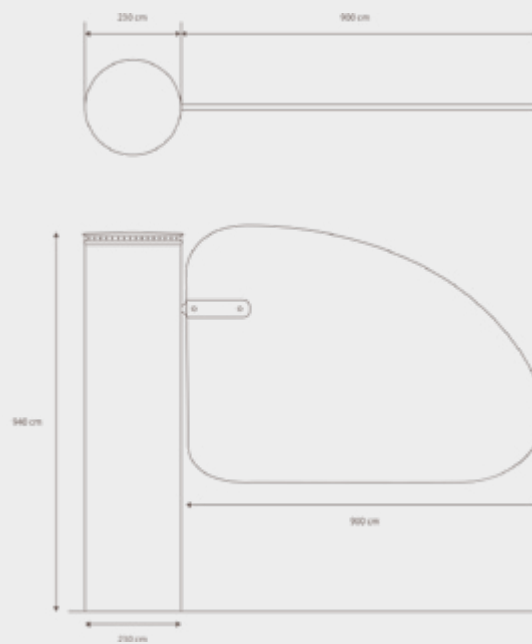
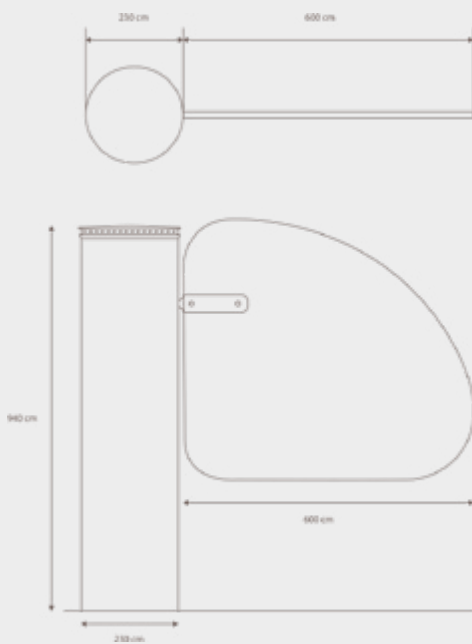

# Horus Tab

 Tablet per rilevazione temperatura corporea e uso mascherina, riconoscimento volti

 Device for body temperature and use of face mask detection, face recognition

 Dispositivo para la detección de la temperatura corporal y la máscara facial, reconocimiento facial

 Dispositif de détection de température corporelle et utilisation du masque, reconnaissance faciale



# Horus Soul

 Sistema di controllo presenze per gestire l'ingresso di un numero limitato di persone

 People counter system to manage the entrance of a limited number of people

 Sistema de control de asistencia para gestionar la entrada de un número limitado de personas

 Système de contrôle de présence pour gérer l'entrée d'un nombre limité de personnes

# Horus



## Horus 600

Cod. 3400600 / € 2.435,00

- Tornello automatico
- Anta in policarbonato 600mm

- Automatic turnstile
- Polycarbonate door 600mm

- Torniquete automático
- Puerta de policarbonato 600 mm

- Tourniquet automatique
- Porte en polycarbonate 600mm

## Horus 900

Cod. 3400900 / € 2.550,00

- Tornello automatico
- Anta in policarbonato 900mm

- Automatic turnstile
- Polycarbonate door 900mm

- Torniquete automático
- Puerta de policarbonato 900 mm

- Tourniquet automatique
- Porte en polycarbonate 900mm

# Horus Tab

## Horus Tab

Cod. 3400010 / € 2.656,00

- Tablet per rilevazione temperatura corporea e uso mascherina, riconoscimento volti

- Device for body temperature and face mask detection, face recognition

- Dispositivo para la detección de la temperatura corporal y la máscara facial, reconocimiento facial

- Dispositif de détection de température corporelle et utilisation du masque, reconnaissance faciale

## Horus Tab Staffa 40

Cod. 3400014 / € 135,00

- Staffa per Tab 40cm

- Bracket for Tab 40cm

- Soporte para Tab 40cm

- Support pour Tab 40cm

## Horus Tab Staffa 110

Cod. 3400015 / € 304,00

- Staffa per Tab 110cm

- Bracket for Tab 110cm

- Soporte para Tab 110cm

- Support pour Tab 110cm

# Horus Soul

## Horus Soul

Cod. 3400020 / € 2.030,00

- Controllo presenze

- People counter system

- Sistema de contador de personas

- Contrôle de présence



# **Accessori**

***Accessories / Accesorios / Accessoires***

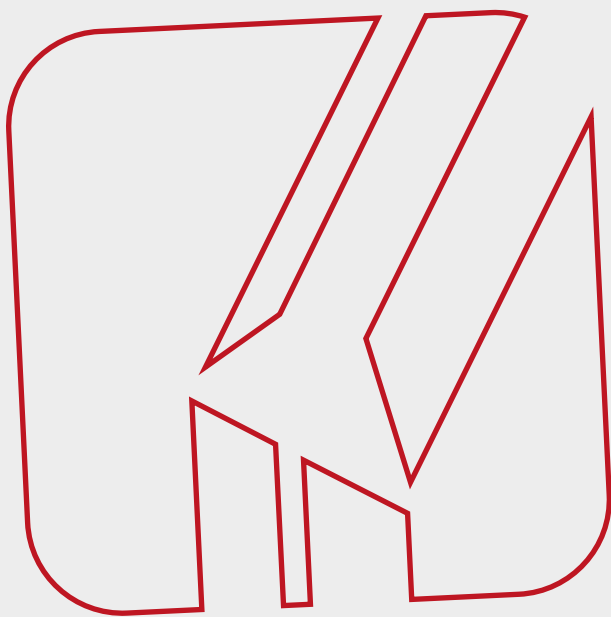

**STAR 2****Cod. 9010002 / € 31,00**

Telecomando bicanale  
433,92 MHz, rolling code

Remote control, rolling  
code 433,92 MHz 2  
channels

Mando a distancia de  
2 canales 433,92 MHz,  
rolling code

Télécommande 2 canaux  
433,92 MHz, rolling code

**STAR 4****Cod. 9010004 / € 34,00**

Telecomando  
quadricanale 433,92 MHz,  
rolling code

Remote control, rolling  
code 433,92 MHz 4  
channels

Mando a distancia de  
4 canales 433,92 MHz,  
rolling code

Télécommande 4 canaux  
433,92 MHz, rolling code

**MARCONI TX4****MARCONI TX4 / € 119,00****LoRa**

Trasmettitore con  
comunicazione bidirezionale  
criptata a 4 canali da  
abbinare al dispositivo  
Marconi Decoder.  
Trasmissione fino 1Km.

4Ch transmitter with 2-way  
encrypted communication  
to be combined with the  
Marconi Decoder device.  
Transmission up to 1Km.

Émetteur avec communication  
bidirectionnelle cryptée  
à 4 canaux à associer au  
dispositif Marconi Decoder.  
Trasmissione hasta 1Km.

Mando con comunicación  
bidireccional encriptada de 4  
canales para combinar con el  
dispositivo Marconi Decoder.  
Trasmissione jusqu'à 1Km.

**MARCONI LINK R4****MARCONI LINK R4 / € 220,00**

Ricevitore a 4 canali con  
antenna

4Ch receiver with  
antenna

Récepteur 4 canaux avec  
antenne

Receptor de 4 canales  
con antena

**REX 20****Cod. 9040000 / € 50,00**

Coppia di fotocellule  
da esterno schermate,  
portata 16m

Pair of external safety  
photocells, 16m range

Par de fotocélulas para  
max 16m

Paire de cellules photo-  
électriques pour max  
16m

**REX 180****Cod. 9040180 / € 55,00**

Coppia di fotocellule  
orientabili 180°, portata  
massima 20m

Pair of rotating  
photocells 180°, 20m  
range

Par de fotocélulas  
orientable 180° alcance,  
max de 20m

Paire de cellules photo-  
électriques rotatives 180°  
pour max 20m

**REX (micro)****Cod. 9040003 / € 45,00**

Micro fotocellula con  
sincronismo e relè REED

Micro photocell with  
synchronism and REED  
relay

Micro photocellule avec  
synchronisation et  
relais REED

Micro fotocélula con  
sincronización y relé  
REED

**REX (incasso)****Cod. 9040005 / € 55,00**

Coppia di fotocellule  
ad incasso 20 mt  
intercambiabile con i  
modelli più diffusi sul  
mercato

Pair of 20 m flush-  
mounted photocells  
interchangeable with the  
most popular models on  
the market

Paire de photocellules  
encastrées de 20 m,  
interchangeables avec  
les modèles les plus  
courants du marché

Par de fotocélulas  
empotrables de 20 m  
intercambiables con los  
modelos más populares  
del mercado

**LUXled / (110V/230V/24V)****Cod. 9030001 / € 48,00**

Lampeggiante a LED con  
24Vdc, 110/230Vac

Flashing light with LED  
and 24Vdc, 110/230Vac

Làmpara destellante a  
LED, antena integrada  
24Vdc, 110/230Vac

Lampe clignotante à LED  
en 24Vdc, 110/230Vac



### FLASH

**Cod. 9030004 / € 48,00**

Lampeggiante universale a 6 LED, multitemensione 112/24/230V

6 LED universal flashing-light, 112/24/230V multi-voltage

Lampe clignotante universel 6 LED, multi-tension 112/24/230V

Lámpara universal de 6 LED, multitempensión 112/24/230V



### FLASH WALL

**Cod. 9030005 / € 48,00**

Lampeggiante universale a 6 LED da parete, multitemensione 12/24/230V

Wall-mounted 6 LED universal flashing-light, multi-voltage 12/24/230V

Lampe clignotante universelle murale à 6 LED, multi-tension 12/24/230V

Lámpara de pared universal de 6 LED, multitempensión 12/24/230V



### LUX MICRO

**Cod. 9030002 / € 48,00**

Lampeggiante a LED da parete con dimensioni estremamente contenute 70 x 27 x 16 mm

Wall-mounted LED flashing light with extremely compact dimensions 70 x 27 x 16 mm

Lampe clignotante murale à LED de dimensions extrêmement réduites 70 x 27 x 16 mm

Lámpara de pared led con dimensiones extremadamente reducidas 70 x 27 x 16 mm



### RADIO 433 - 4Ch

**Cod. 9020000 / € 74,00**

Ricevente 4Ch 433,92 MHz, rolling code

4Ch receiver 433,92 MHz, rolling code

Receptor 4Ch 433,92 MHz, rolling code

Récepteur 4Ch 433,92 MHz, rolling code



### COL50 - 0,5 m

**Cod. 9085000 / € 75,00**

Coppia di colonnine per fotocellule, altezza 50 cm

Pair of pillars for photocells, 50cm height

Par de colonnes para fotocélulas, altura 50cm

Paire de colonnes pour cellules photo-électriques, hauteur 50cm



### AIR - 3 m

**Cod. 9312000 / € 40,00**

Antenna 433,92 MHz con cavo di 3 m

Antenna 433,92 MHz with 3m long cable

Antena 433,92 MHz con cable de 3m

Antenne 433,92 MHz avec cable de 3m



### COMEC15 - 1,5 m

**Cod. 9317000 / € 83,00**

Costa meccanica lunga 1500 mm

Safety mechanical edge 1500mm long

Costa mecànica 1500 mm de largo

Barre palpeuse mécanique de 1500 mm



### DIGIKEY - Rolling code 433,92MHz

**Cod. 9060000 / € 100,00**

Dispositivo radio per il comando locale dell'automazione con tastierino numerico

Radio device for local automation control with numeric keypad

Dispositivo radio con digitación para la apertura a distancia de un automatismo

Appareil radio pour le contrôle de l'automatisation locale avec pavé numérique



### SEF

**Cod. 9060010 / € 244,00**

Semaforo di segnalazione a LED multitemensione (12/24 Vdc) a due lenti: verde e rossa

Multi-voltage LED signal light (12/24 Vdc) with two lenses: green and red

Feu de signalisation LED multi-tension (12/24 Vdc) avec deux lentilles: verte et rouge

Luz de señalización LED multitempensión (12/24 Vcc) con dos lentes: verde y roja

### SEF CONTROL

**Cod. 9060011 / € 240,00**



Centrale di gestione impianti semaforici a due vie (max 2 semafori a due o tre luci 24V o 230V)

Two-way traffic light control unit (max. 2 traffic lights with two or three lights 24V or 230V)

Centrale de commande de feux de signalisation à double sens (max. 2 feux de signalisation à deux ou trois feux 24V ou 230V)

Cuadro de maniobra de semáforos bidireccional (máx. 2 semáforos con dos o tres luces 24V o 230V)



# Condizioni di vendita

## Listino

Il presente listino annulla e sostituisce i precedenti.

## Garanzia

La garanzia ha durata di 24 mesi per le componenti meccaniche e 12 mesi per le componenti elettroniche. È limitata esclusivamente alla riparazione o sostituzione gratuita dei pezzi ritenuti difettosi. Eventuali resi dovranno essere prima concordati con DPLUS SRLS e solo a seguito spediti in porto franco al nostro indirizzo. Non sarà accettato alcun reso se spedito in porto assegnato. La nostra garanzia decadrà nel caso in cui la merce resa come difettosa sia stata manomessa o riparata da personale non qualificato.

## Prezzi

Tutti i prezzi sono al netto di iva. I prezzi si intendono per merce resa franco nostra sede. DPLUS SRL si riserva il diritto di variare i prezzi qualora ne corso della fornitura si dovessero verificare mutamenti di costi non imputabili a DPLUS SRL stessa.

## Consegna

Il trasporto della merce avviene a rischio e pericolo del committente, anche se in porto franco. Non si accettano reclami una volta trascorsi 10 giorni dal ricevimento della merce. DPLUS SRL non si assume alcuna responsabilità per danni derivanti da ritardi di consegna. Il termine di consegna da noi confermato deve intendersi indicativo e senza impegno. In particolare, il termine di consegna si intende prorogato per: difficoltà di approvvigionamento materie prime, scioperi totali o parziali nei nostri stabilimenti o in quelli dei nostri fornitori, cause di forza maggiore.

## Pagamento

Ci riserviamo la facoltà, in caso di mancato o ritardato pagamento, di sospendere la consegna delle forniture ancora in ordine, dandone avviso al committente, senza che da ciò possa derivare alcun diritto di eventuali rimesse e fatto salvo il riconoscimento alla nostra società delle spese sostenute. Ci riserviamo la proprietà dei nostri prodotti forniti finché tutti i nostri crediti derivanti dal rapporto di affari non saranno stati saldati.

## Foro competente

Per ogni controversia è competente solamente il foro di Vicenza. DPLUS SRL declina ogni responsabilità per eventuali danni o lesioni causati, direttamente o indirettamente, a persone, cose ed animali conseguentemente alla mancata osservanza di tutte le indicazioni descritte nel manuale di istruzioni allegato ad ogni prodotto di DPLUS SRL.

## Avvertenze

DPLUS SRLS si riserva il vaglio dell'autorizzazione di qualsivoglia riproduzione a catalogo (foto e/o disegni) dei suoi prodotti; qualora autorizzate, le riproduzioni non devono confondere sull'identità dell'azienda produttrice. Inoltre la suddetta si avvale dell'imprescindibile facoltà di nominare i suoi venditori o rappresentanti, diffidando chiunque si proponga senza previa autorizzazione.

## Conformità alle norme UE

Tutti i nostri prodotti sono conformi ai requisiti delle direttive applicabili dal Consiglio dell'Unione Europea. Le dichiarazioni di conformità sono depositate presso DPLUS SRL.

*DPLUS SRL si riserva il diritto di apportare tutte le modifiche che riterrà opportuno al fine di migliorare i prodotti presenti nel presente catalogo.*

*Le illustrazioni e fotografie sono puramente indicative. È vietato l'uso e la riproduzione anche parziale del materiale qui presentato. Tutti i diritti sono riservati.*

# General sale conditions

## Price list

This price list erases and substitutes the previous ones.

## Warranty

Our warranty lasts 24 months for the mechanical components and 12 months for the electronic components. The warranty regards exclusively the repairation or the substitution of the defective products. Every rejection must be agreed at first with DPLUS SRL. The goods must be sent free on board to our address. Any rejected products, not sent to us on free on board won't be accepted. If the goods are tempered or repaired by unqualified people, DPLUS' s warranty will decline.

## Prices

The prices are net of Vat and regard finished products which are handed over in our factory. If it happens that during the supply the costs change quite apart from DPLUS's will, we have the right to modify our prices.

## Delivery

The purchaser will take the risk and danger of the conveyance, even if it is free on board. Complaints 10 days after goods receipt are not accepted. DPLUS SRL is not responsible for possible damages caused by delays in delivery. The delivery time is indicative and without any obligation on our part. Moreover, it can be extended for these reasons: difficulties to get the raw material, total or partial strikes of our employees or of our suppliers, other serious causes.

## Payment

In case of delayed or missing payment we reserve the right to stop the delivery of the supplies still in order, by informing the purchaser who can't claim any compensation but who has to support our possible charges. Moreover, we have the right to keep the ownership of the goods until the complete settlement of the debts.

## Court of competent jurisdiction

For any controversy you have to apply to the Court of Vicenza-Italy. DPLUS SRL is not responsible for possible damages to people, things and animals caused by a non-observance of the indications written in the manual for a right usage and upkeep of DPLUS's products.

## Warnings

Every kind of catalogue reproductions, such as photos, figures or drawings of any DPLUS's products, has to be weight and authorized by the company; whenever authorized the reproductions don't have to cause confusion on DPLUS identity. In addition, DPLUS appeals to the unquestionable right of nominating its own sellers or agents, disclaiming everyone who takes DPLUS's place without any authorization.

## Conformity to the directives UE

All our products fully fulfill the official instructions by the European Union Council. The declaration of conformity can be found at DPLUS SRLS.

*DPLUS SRL reserves the right to make every opportune change in order to improve its products appearing in this catalogue.*

*The pictures and photographs are just as an indication. Every use and reproduction of the here mentioned products, or of part of them, is forbidden. All rights are reserved.*



# Condizioni de ventas

## **Lista de precios**

La presente lista de precios anula y sustituye las antecedentes.

## **Garantía**

La garantía ofrecida es de 24 meses por las componentes mecánicas y 12 meses por las electrónicas. La garantía está limitada exclusivamente a la reparación o sustitución gratuita de las piezas defectuosas. Eventuales devoluciones tendrán que concordarse con DPLUS SRL, luego enviadas con porte pagado a nuestra dirección. No se aceptarán devoluciones enviadas con porte debido. La garantía DPLUS decaerá en cuanto las piezas devueltas hayan sido forzadas o reparadas por personal no calificado.

## **Precios**

Todos los precios son sin IVA. Los precios son por mercancía con porte debido. En caso de que durante el suministro vayan verificándose mutaciones de precios no imputables a DPLUS SRL, nos reservamos el derecho de variar nuestros precios.

## **Entrega**

El transporte de la mercancía está bajo la responsabilidad del cliente, con porte pagado también. No se aceptarán reclamaciones pasados 10 días del recibo de la mercancía. DPLUS SRL no se asume responsabilidades por daños que deriven de un atraso en los tiempos de entrega. El tiempo de entrega confirmado por nosotros es indicativo y sin compromiso, puede ser prorrogado por dificultades en el abastecimiento de las materias primas; huelgas totales o parciales en nuestra fábrica o en las de nuestros proveedores; por fuerza mayor.

## **Pago**

Nos reservamos el derecho, en caso de falta o atraso de pago, de suspender la entrega de la mercancía aun pendientes, avisando al cliente, sin que por eso hayan derechos de revancha y reconociendo a nuestra empresa los gastos sostenidos. Nos reservamos la propiedad de nuestros productos entregados, hasta el saldo de todos nuestros créditos derivante de la relación comercial.

## **Fuera competente**

Por cada controversia queda competente únicamente el Tribunal de Vicenza. DPLUS SRL declina cada responsabilidad por eventuales daños o lesiones, directamente o indirectamente, a individuos, cosas y animales en caso de no observar todas las indicaciones descritas en el manual de instrucciones adjunto a cada producto DPLUS.

## **Advertencias**

Corresponde a DPLUS SRL el criba de la autorización de cualquier reproducción en catálogo (fotos y/o dibujos) de sus productos; si autorizadas, las reproducciones no tienen que generar confusión sobre la identidad de la empresa fabricante. Además, DPLUS SRL se acoge la imprescindible facultad de nominar sus vendedores o representantes, desconfianza cualquiera se presente sin previa autorización.

## **Conformidad con las normas UE**

Todos nuestros productos están hechos en conformidad con las disposiciones aplicables por el Consejo de la Unión Europea. Las declaraciones de conformidad están depositadas cerca de DPLUS SRL.

*DPLUS SRL se reserva el derecho de hacer todas las modificaciones necesarias para mejorar los productos que se encuentran en este catálogo.*

*Las imágenes y las fotos tienen un valor solamente indicativo. La reproducción y el uso de todo o parte del material aquí presente está prohibido. Todos los derechos son reservados.*

# Conditions générales de vente

## **Liste de prix**

Cette liste de prix annule et remplace les précédentes.

## **Garantie**

Nous offrons une garantie de 24 mois pour les éléments mécaniques et 12 mois pour les éléments électroniques. La garantie est limitée exclusivement à la réparation ou au remplacement gratuit des pièces défectueuses. Retours éventuels devront être d'abord déterminés avec DPLUS SRL, ensuite livrés en port payé à notre adresse. Aucune pièce ne sera acceptée si envoyée en port dû. Notre garantie ne prendra pas effet au cas où les pièces rendues comme défectueuses ont été contrefaites ou réparées par du personnel non compétent.

## **Prix**

Tous les prix sont Tva excluse. Le prix sont pour marchandise départ notre usine. Nous nous réservons le droit de modifier nos prix.

## **Livraison**

Le matériel voyage à la charge et aux risques du client, même en port payé. Nous n'acceptons aucune réclamation après 10 jours date de réception de la marchandise. DPLUS SRL n'accepte aucune responsabilité pour des dommages dus au transport ou au retard de livraison. Le délai de livraison que nous confirmons doit être considéré comme indicatif, départ usine et sans engagement. En particulier, le délai de livraison peut être prorogé pour: difficulté d'approvisionnement en matières premières; grèves totale ou partielle en de nos établissements ou ceux de nos fournisseurs; causes de force majeure.

## **Payement**

Nous nous réservons la faculté, en cas de paiement retardé ou de non-paiement, de suspendre la livraison des fournitures encore en commande, en avertissant le client, cela ne donne aucun droit de recours éventuels, sauf la reconnaissance à notre société des frais engendrés. Nous nous réservons la propriété de nos produits fournis jusqu'au moment où tous nos crédits qui dérivent du rapport d'affaires n'auront pas été réglés.

## **Tribunal compétent**

Pour chaque différend le tribunal compétent est celui de Vicenza. DPLUS SRL décline toute responsabilité pour les dommages éventuels ou lésions causées, directement ou indirectement, à personnes, choses ou animaux par suite de l'inobservation de toutes les indications décrites dans le manuel d'instruction qui suit chaque produit de DPLUS.

## **Advertissements**

C'est à DPLUS SRL l'examen de l'autorisation de n'importe quelle reproduction du catalogue (photos et/ou dessins) de ses produits; si autorisées, les reproductions ne doivent pas être confondues sur l'identité de la société constructrice. De plus, la susdite conseil de la faculté don't il faut tenir compte de nommer ses vendeurs ou représentants, de se méfier de qui se propose sans autorisation préalable.

## **Conformité aux normes UE**

Tous nos produits sont conformes aux qualités requises par les directives applicables par le Conseil de l'Union Européenne. Les déclarations de conformité aux qualités requises sont déposées chez DPLUS SRL.

*DPLUS SRL se réserve le droit d'apporter toutes les modifications qui puissent être nécessaires pour améliorer les produits présents dans ce catalogue.*

*Les images et les photos ont un valeur purement indicative. Toute utilisation ou reproduction de tout ou partie du matériel ici présenté est interdite. Tous les droits sont réservés.*

***www.dplusitalia.it***



***Dplus Srl***

Sede legale:

Via Cementi 5, 36015 Schio (VI)

Sede operativa:

V.le Dell'Industria 118, 36015 Schio (VI)

P.iva 04038860245

*info@dplusitalia.it / ph +39 0445 1716455*